

Step 1: Excavate trench and install sediment wattles
 Step 2: Backfill soil against sediment wattles

PROPERLY STAKED AND ENTRENCHED SEDIMENT WATTLE

WATTLE SPACING	
Slope	Spacing (m)
1:4 or flatter	12
1:3	9
1:2	6
1:1	3

STAKES REQUIRED	
Wattle length (m)	Stakes required for each wattle
7.5	8
6.0	6
3.5	4

- NOTE:**
1. Drive stakes at each end and at 1.2 m spacing until wattle is secure to slope. Live stakes may be used for permanent installations. Do not crush wattle while staking.
 2. Overlap wattles 300 mm minimum. Drive stakes at 150 mm from wattle end angles towards the adjacent wattle and space stakes at 1.2 meters max.
 3. Dimensions without units are millimeters.

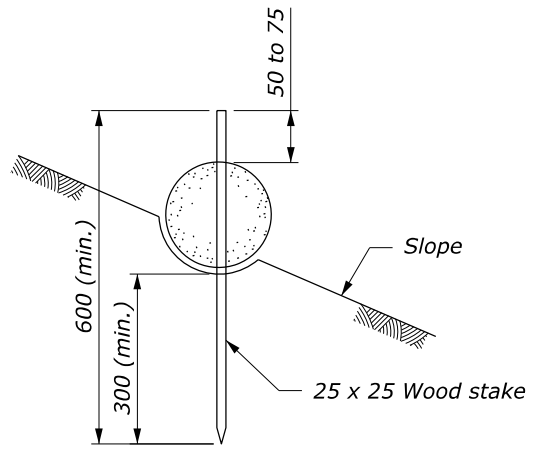

SEDIMENT WATTLE STAKING DETAIL

INSTALLATION BEYOND TOE OF SLOPE

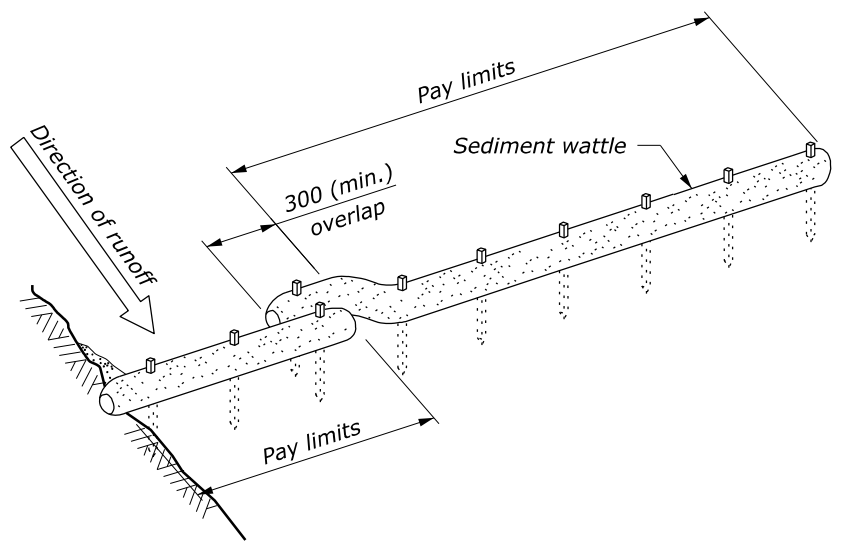

**ALTERNATE SEDIMENT WATTLE JOINT DETAIL
SLOPE PROTECTION INSTALLATION**

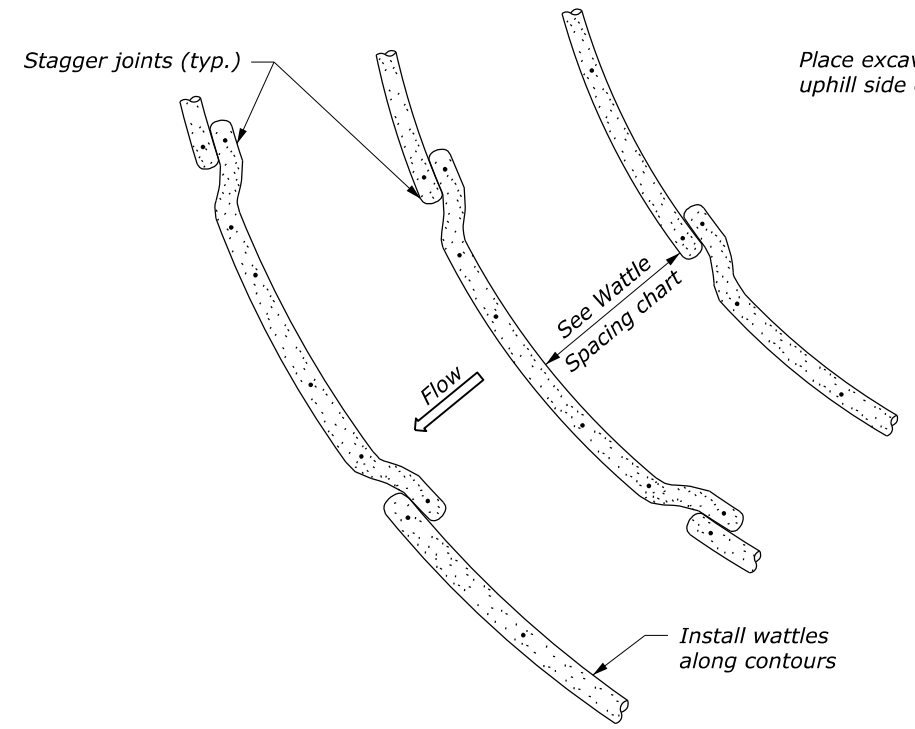

INSTALLATION ALONG SLOPES

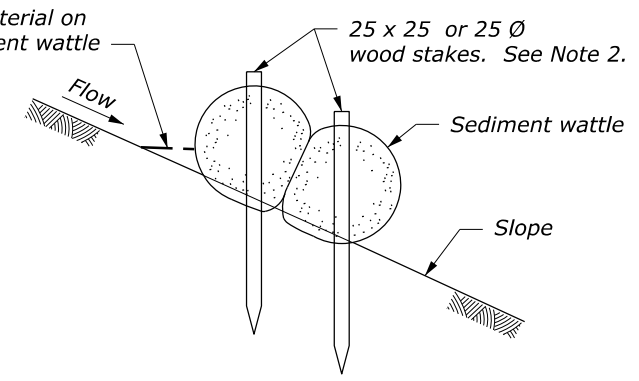

SEDIMENT WATTLE LAPPING DETAIL

U.S. DEPARTMENT OF TRANSPORTATION FEDERAL HIGHWAY ADMINISTRATION OFFICE OF FEDERAL LANDS HIGHWAY	
WFLHD METRIC DETAIL	
SEDIMENT WATTLE	
DETAIL APPROVED FOR USE 10/2014 REVISED: 7/2016	DETAIL WM157-20

NO SCALE