

PLAN OF TYPE A APPROACH

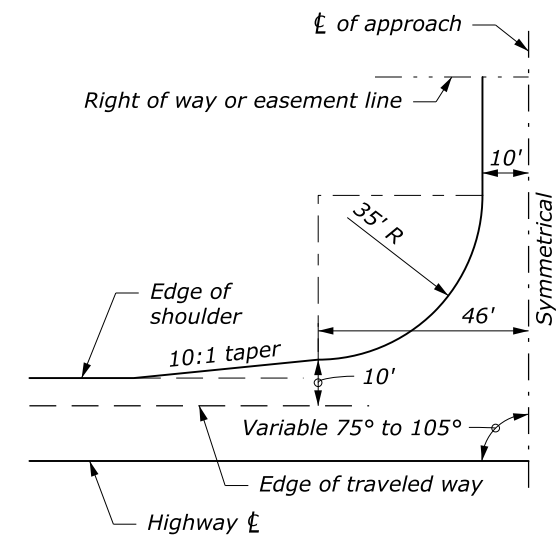

PLAN OF TYPE B APPROACH

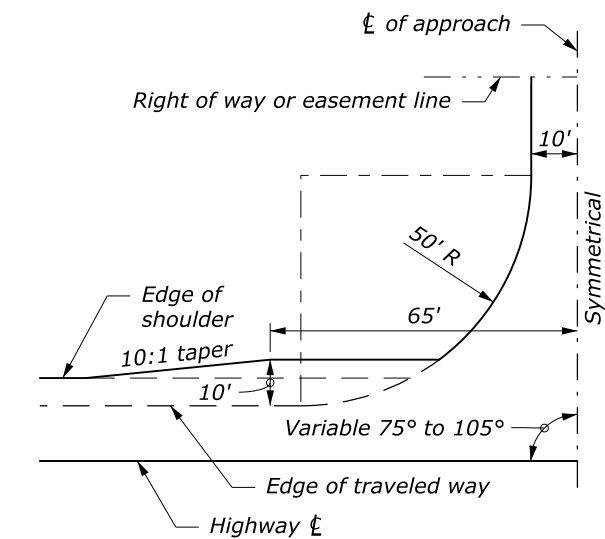

PLAN OF TYPE C APPROACH

- NOTE:**
1. Continue approach radius as required if connection to existing alignment of new approach is at an angle.
 2. Finish type D and M approaches with the same treatment as shown for the adjacent roadbed.
 3. Finish other approaches with the same treatment as shown on the adjacent roadbed, except that the surface course shall not exceed 1 1/2 inch depth.
 4. Extend paving to the right-of-way or easement line unless otherwise shown on the plans.
 5. Construct side slope ratios and finish approaches compatible with the adjacent roadway construction.

TYPE M INTERSECTION DATA								
SKEW θ	Δ1	Δ2	T1 ft	T2 ft	T3 ft	T4 ft	Area A sqyd	Area B sqyd
75°	67°35"	105°	36.81	71.68	131.74	55.20	157	130
76°	68°35"	104°	37.51	70.40	132.74	55.91	160	125
77°	69°35"	103°	38.21	69.14	133.75	56.64	163	120
78°	70°35"	102°	38.93	67.92	134.77	57.38	166	116
79°	71°35"	101°	39.66	66.72	135.80	58.13	169	111
80°	72°35"	100°	40.39	65.55	136.84	58.90	173	107
81°	73°35"	99°	41.13	64.40	137.89	59.69	176	103
82°	74°35"	98°	41.89	63.27	138.95	60.49	179	99
83°	75°35"	97°	42.65	62.17	140.02	61.31	183	95
84°	76°35"	96°	43.42	61.08	141.10	62.15	187	92
85°	77°35"	95°	44.21	60.02	142.20	63.00	191	88
86°	78°35"	94°	45.00	58.98	143.31	63.88	194	85
87°	79°35"	93°	45.81	57.96	144.44	64.77	198	81
88°	80°35"	92°	46.63	56.95	145.57	65.68	203	78
89°	81°35"	91°	47.46	55.97	146.73	66.61	207	75
90°	82°35"	90°	48.30	55.00	147.90	67.56	211	72
91°	83°35"	89°	49.16	54.05	149.09	68.53	216	69
92°	84°35"	88°	50.03	53.11	150.29	69.52	220	66
93°	85°35"	87°	50.92	52.19	151.52	70.53	225	64
94°	86°35"	86°	51.81	51.29	152.76	71.57	230	61
95°	87°35"	85°	52.73	50.40	154.02	72.63	235	59
96°	88°35"	84°	53.66	49.52	155.30	73.71	240	56
97°	89°35"	83°	54.60	48.66	156.61	74.82	245	54
98°	90°35"	82°	55.56	47.81	157.94	75.95	251	52
99°	91°35"	81°	56.54	46.97	159.29	77.11	257	49
100°	92°35"	80°	57.54	46.15	160.66	78.30	263	47
101°	93°35"	79°	58.55	45.34	162.06	79.51	269	45
102°	94°35"	78°	59.59	44.54	163.49	80.76	275	43
103°	95°35"	77°	60.64	43.75	164.94	82.03	281	42
104°	96°35"	76°	61.71	42.97	166.43	83.34	288	40
105°	97°35"	75°	62.81	42.20	167.94	84.68	295	38

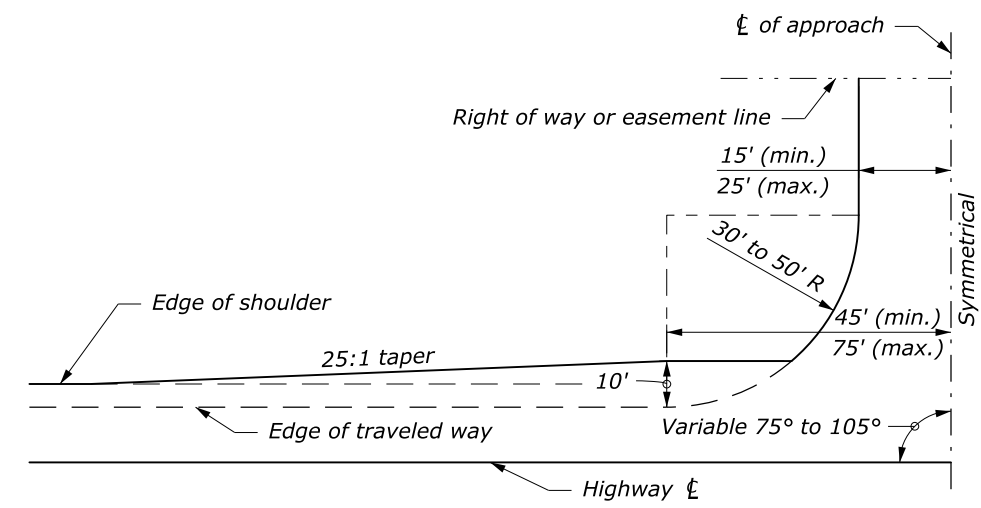

PLAN OF TYPE D APPROACH

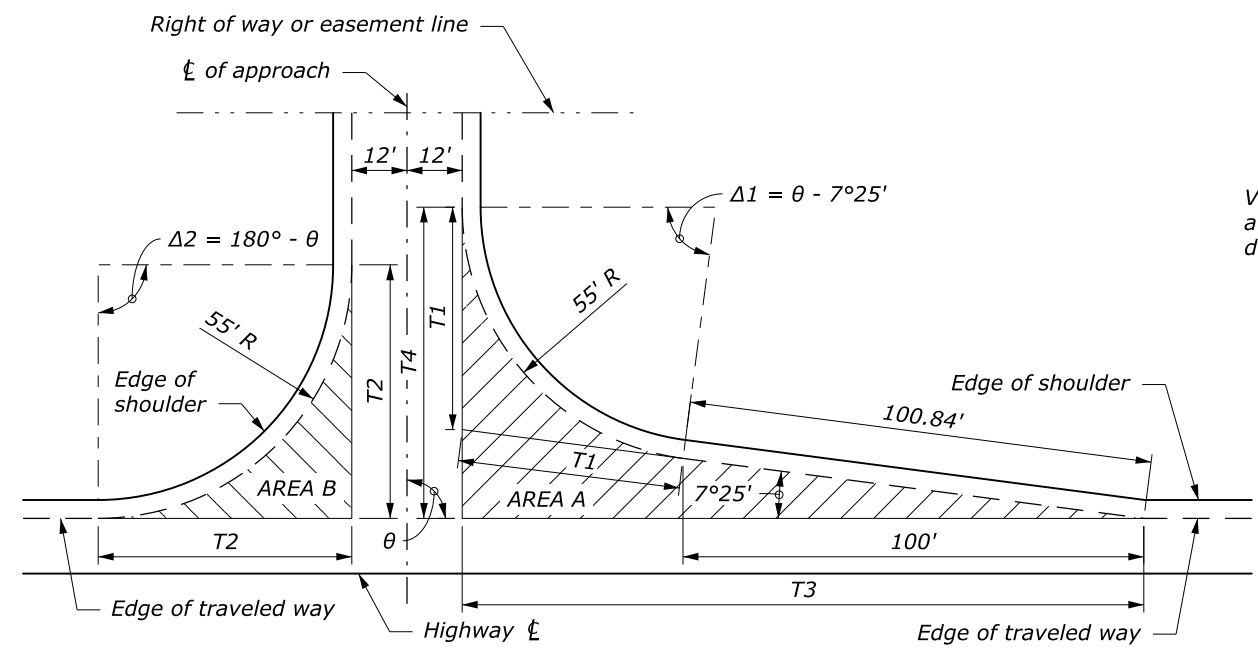

PLAN OF TYPE M APPROACH

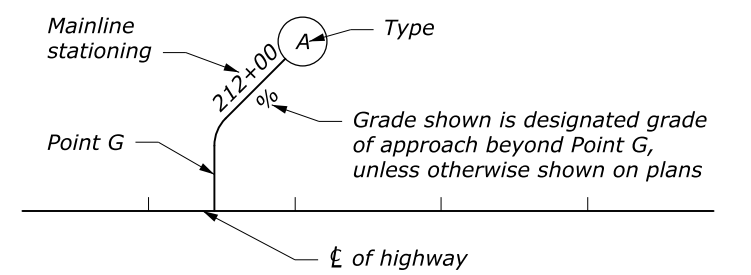

ROAD APPROACH LOCATIONS ON PLAN SHEETS

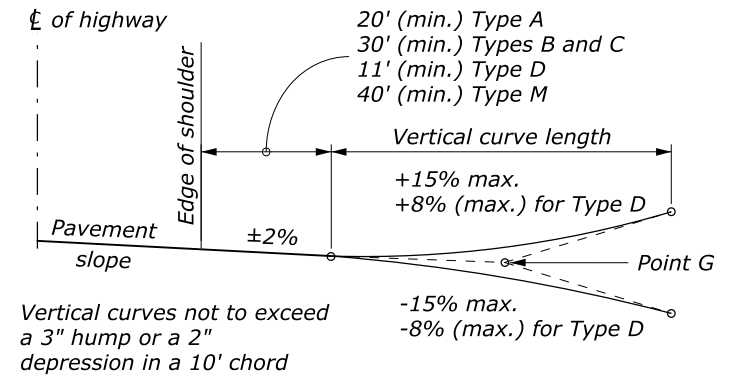

PROFILE OF TYPE A, B, C, D, M APPROACHES

U.S. DEPARTMENT OF TRANSPORTATION
FEDERAL HIGHWAY ADMINISTRATION
WESTERN FEDERAL LANDS HIGHWAY DIVISION

U.S. CUSTOMARY DETAIL

WASHINGTON ROAD APPROACH

DETAIL APPROVED FOR USE 2/2004

REVISOR: DRAFT: 11/2014

DETAIL W200-80

NO SCALE