

NOTE:
 1. Steel is ASTM A242 or A588, Grade 50.
 2. Concrete: minimum $f_c' = 3500$ psi.

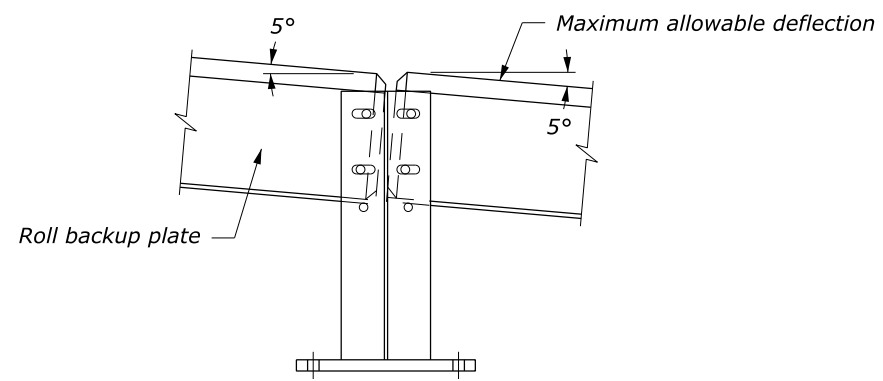

**ENDS OF RAILS AT POST:
 MAXIMUM VERTICAL
 DEFLECTION ALLOWABLE
 ELEVATION**

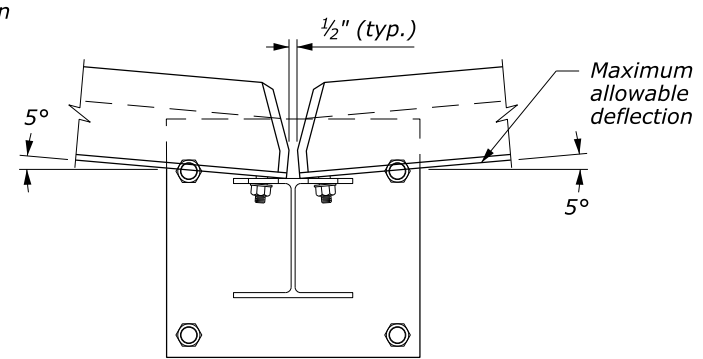

**MAXIMUM HORIZONTAL
 DEFLECTION ALLOWABLE
 PLAN VIEW**

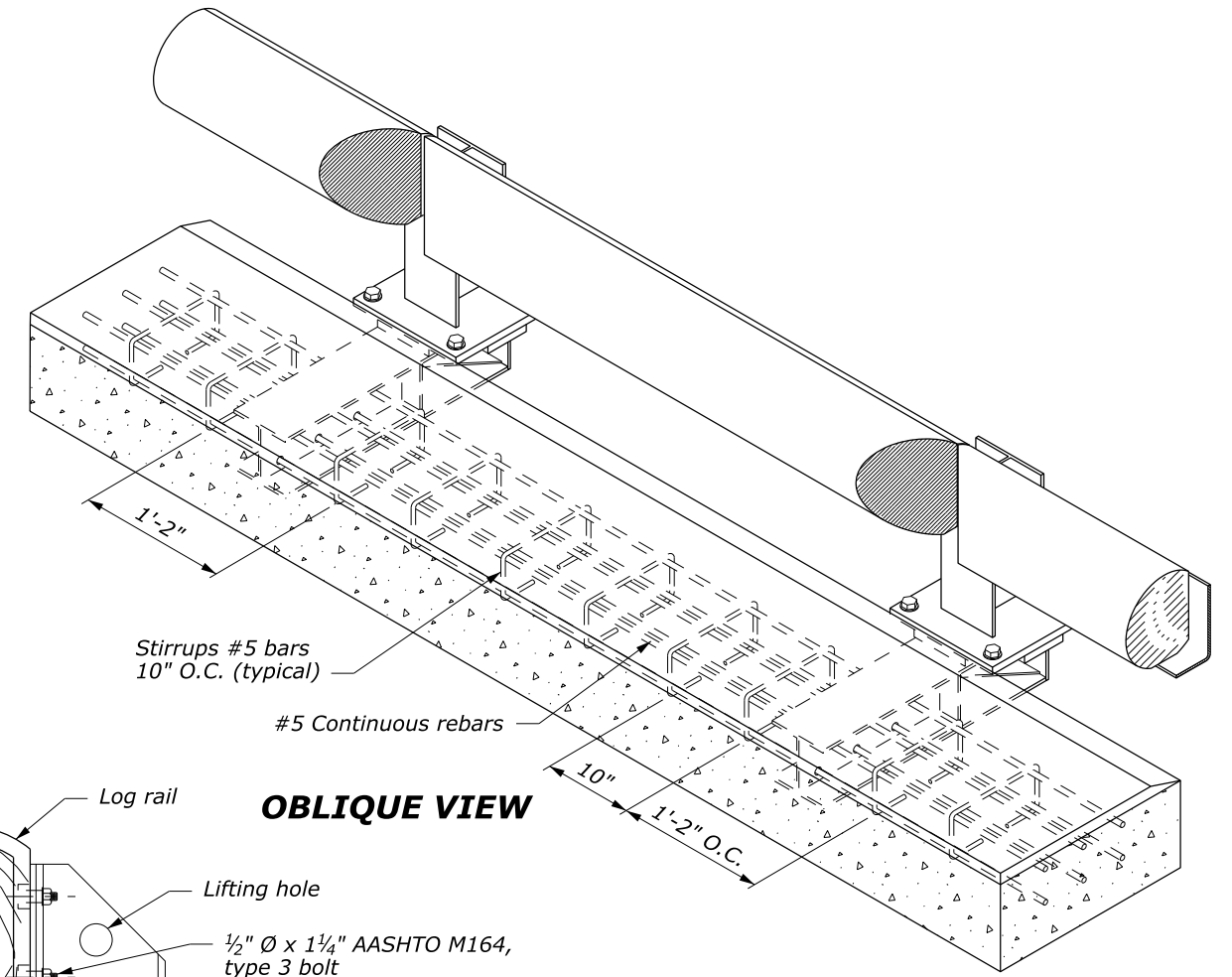

OBLIQUE VIEW

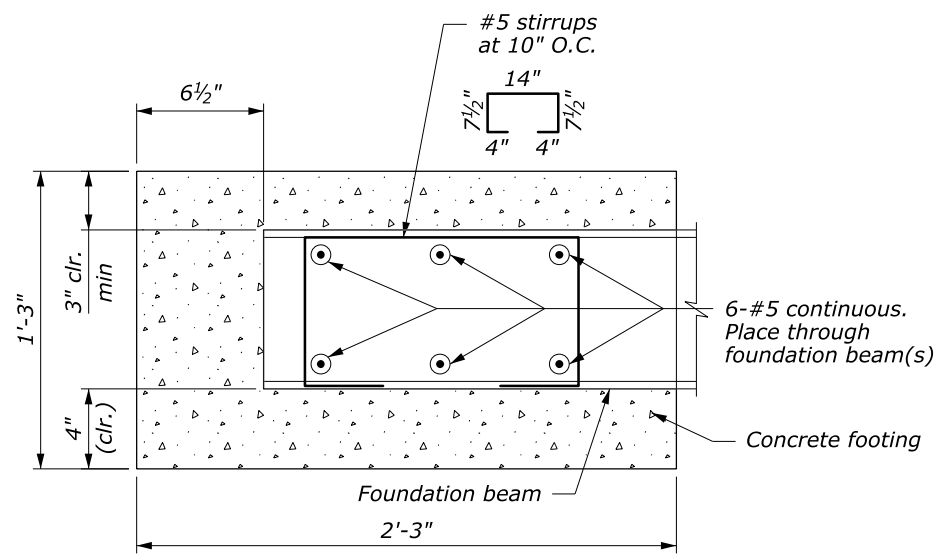

**FOOTING DETAIL
 TYPICAL SECTION**

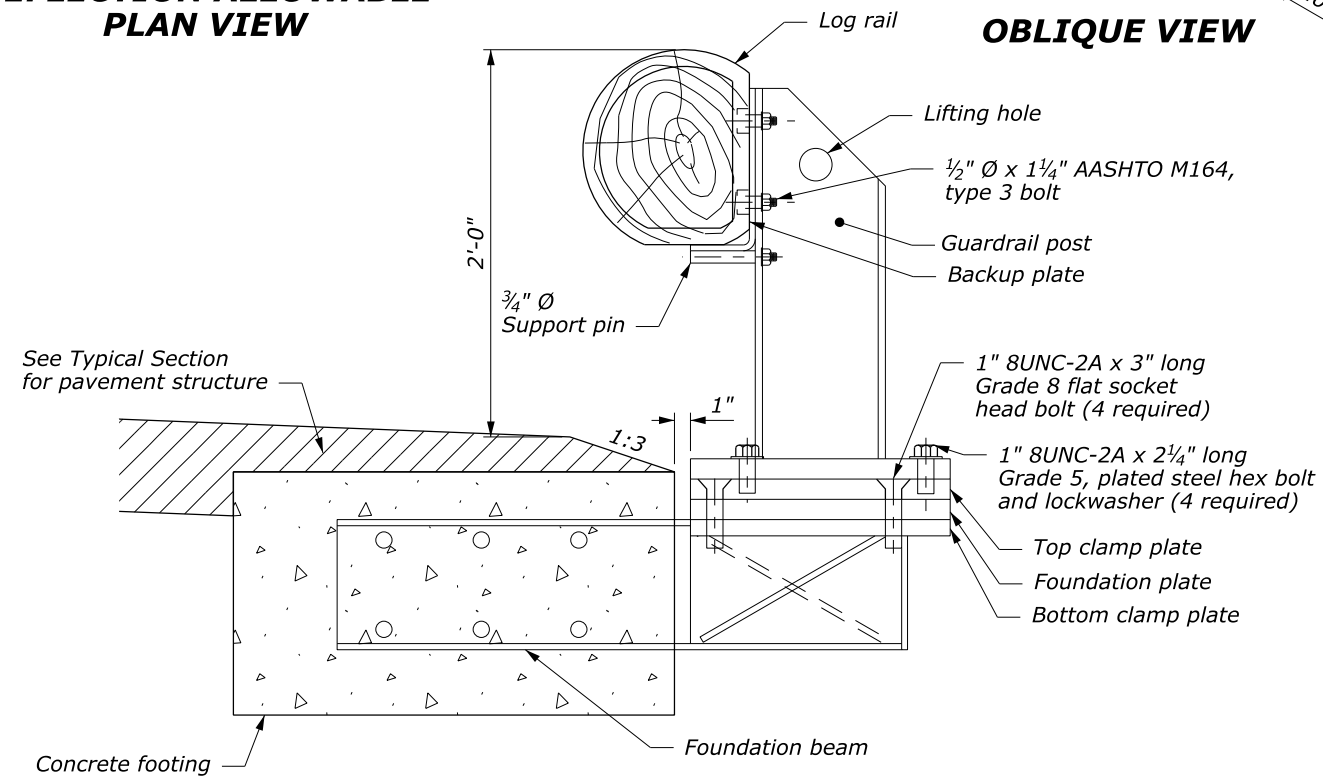

TYPICAL SECTION

NO SCALE

U.S. DEPARTMENT OF TRANSPORTATION FEDERAL HIGHWAY ADMINISTRATION WESTERN FEDERAL LANDS HIGHWAY DIVISION	
U.S. CUSTOMARY DETAIL REMOVABLE STEEL-BACKED LOG RAIL Sheet 1 of 3	
DETAIL APPROVED FOR USE 3/2009 REVISED:	DETAIL W617-83

18 November 2014 8:42 AM c:\myfiles\pw_production\dms43646\Det.W617-83.dgn [USC]

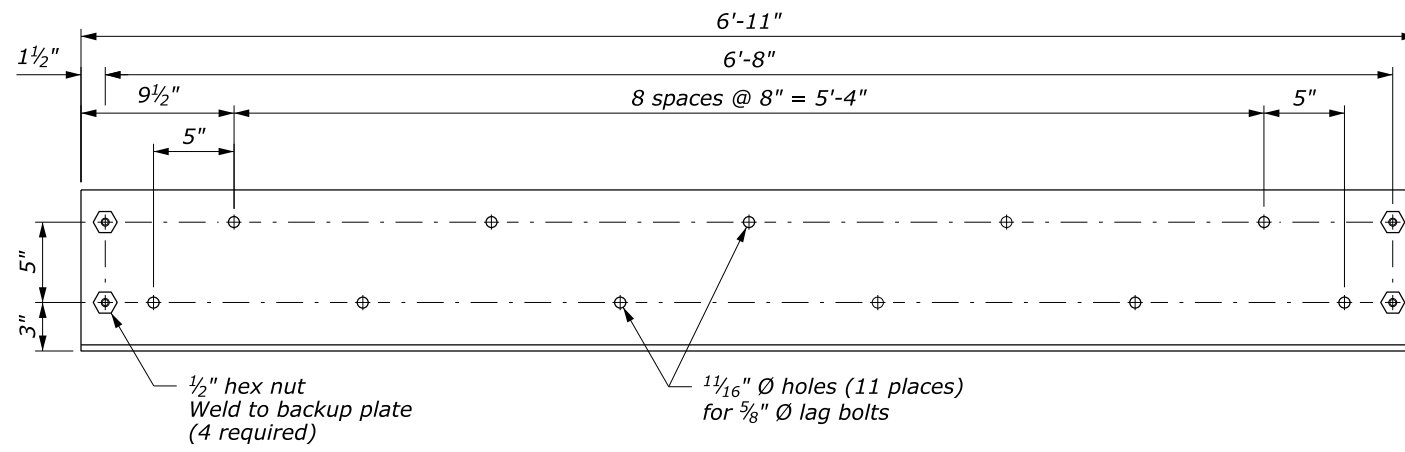

**RAIL BACKUP PLATE
ELEVATION VIEW**

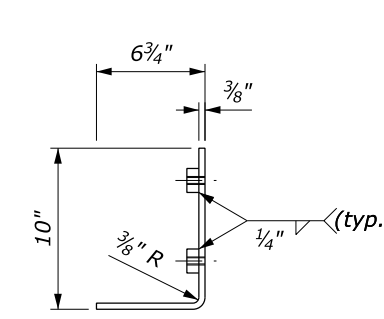

**RAIL BACKUP PLATE
SECTION VIEW**

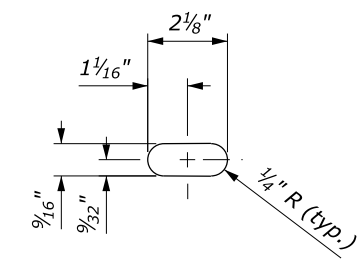

TYPICAL SLOT DETAIL

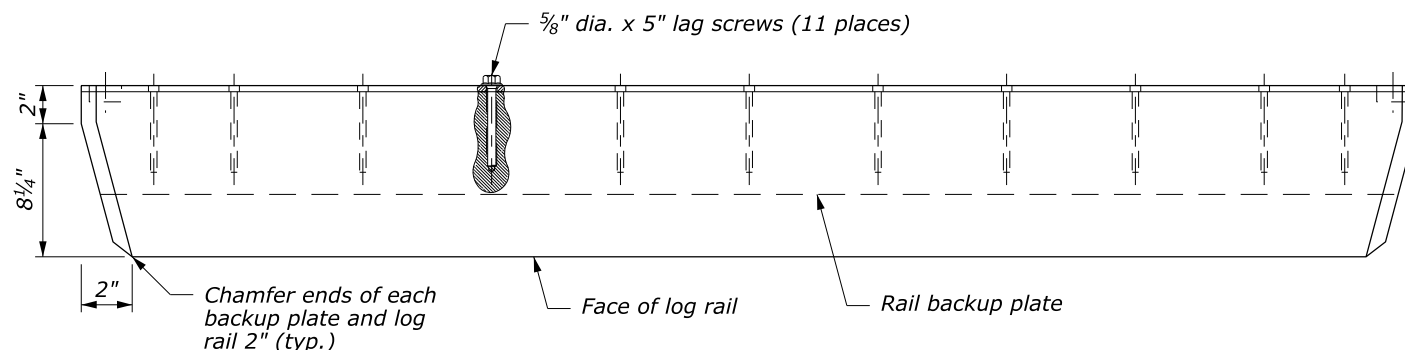

**LOG RAIL & RAIL BACKUP PLATE
PLAN VIEW**

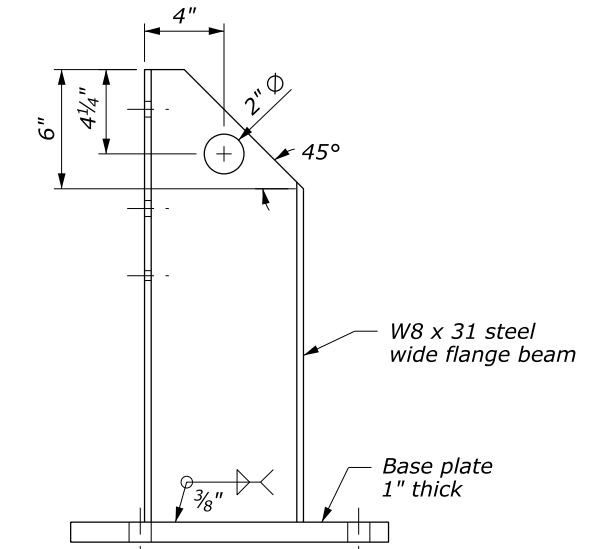
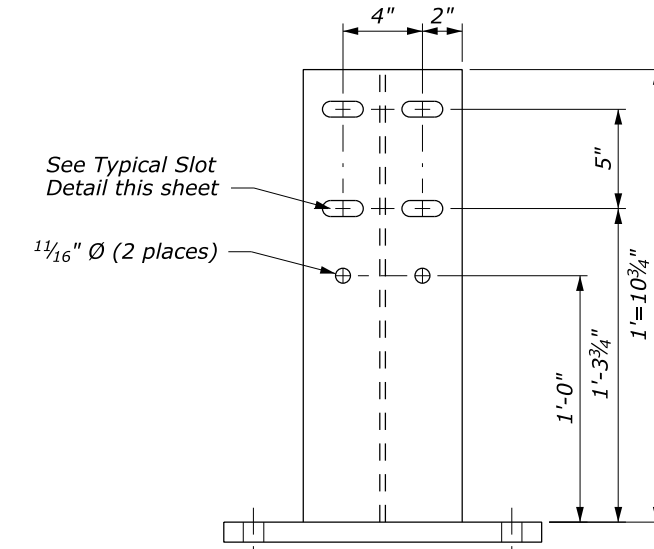

GUARDRAIL POST

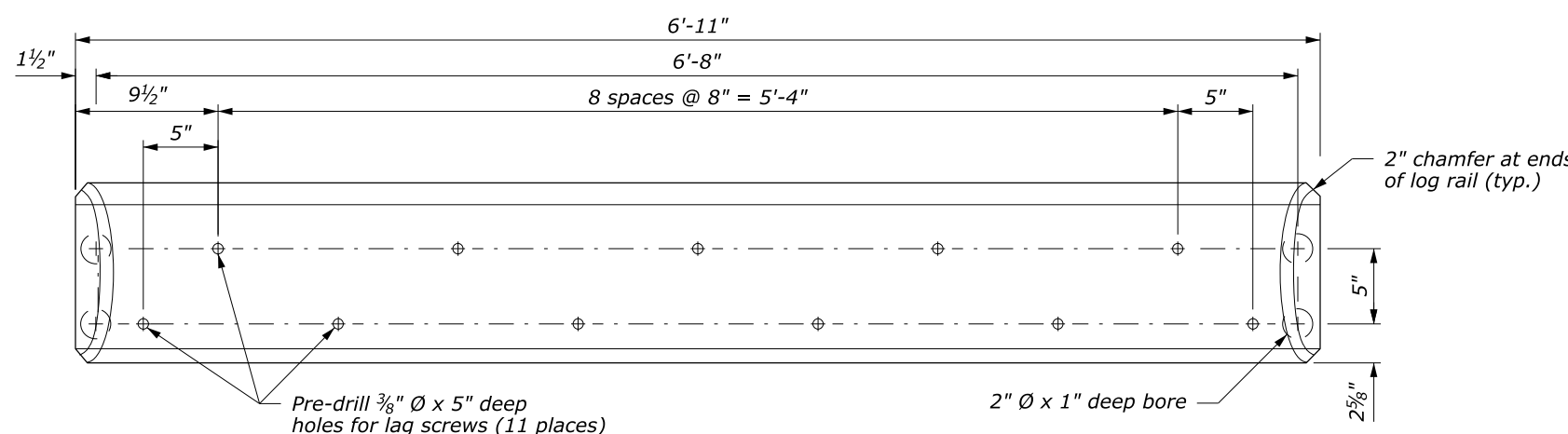

**LOG RAIL
ELEVATION VIEW**

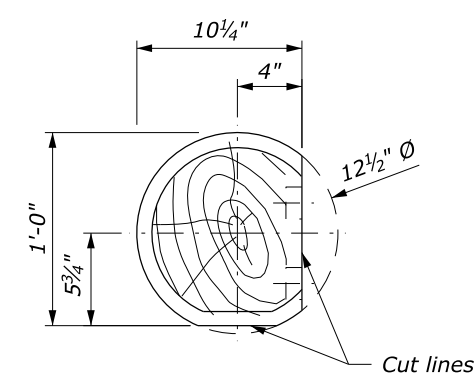

**LOG RAIL
SECTION VIEW**

NO SCALE

U.S. DEPARTMENT OF TRANSPORTATION FEDERAL HIGHWAY ADMINISTRATION WESTERN FEDERAL LANDS HIGHWAY DIVISION	
U.S. CUSTOMARY DETAIL REMOVABLE STEEL-BACKED LOG RAIL Sheet 2 of 3	
DETAIL APPROVED FOR USE 3/2009	DETAIL
REVISED:	W617-83

18 November 2014 8:42 AM c:\myfiles\pw_production\dms43646\Det.W617-83.dgn [USC]

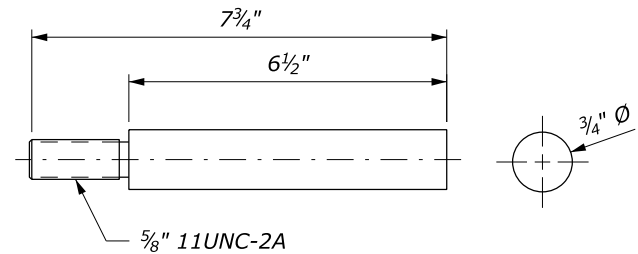

SUPPORT PIN

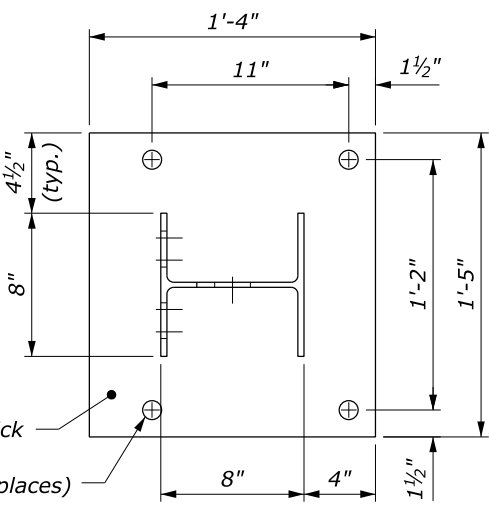
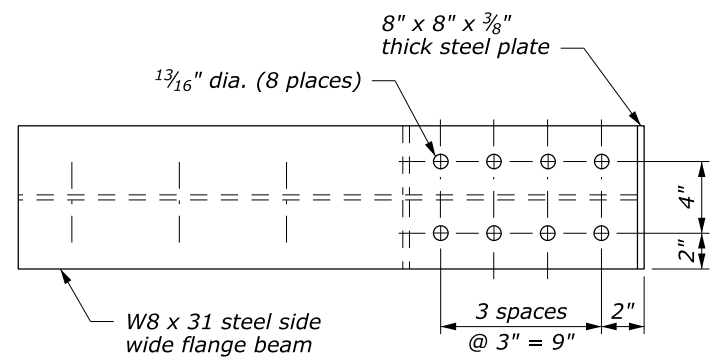

RAIL POST BASE PLATE

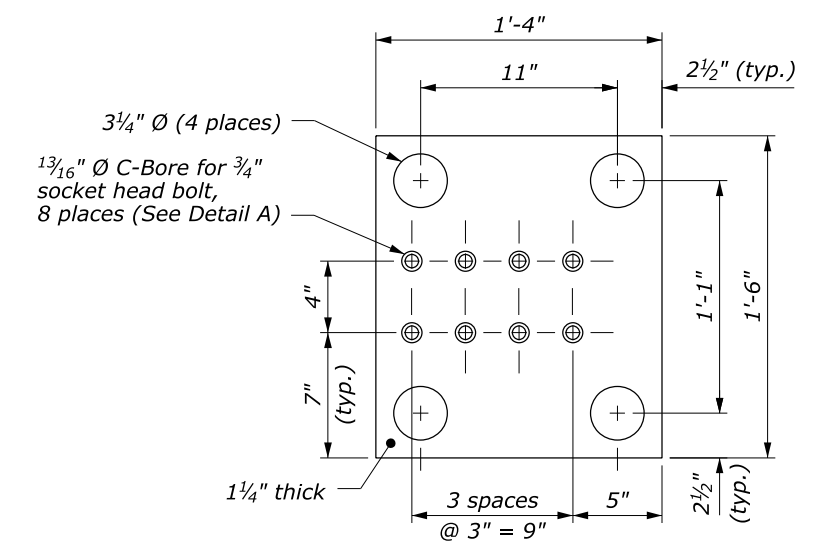

FOUNDATION PLATE

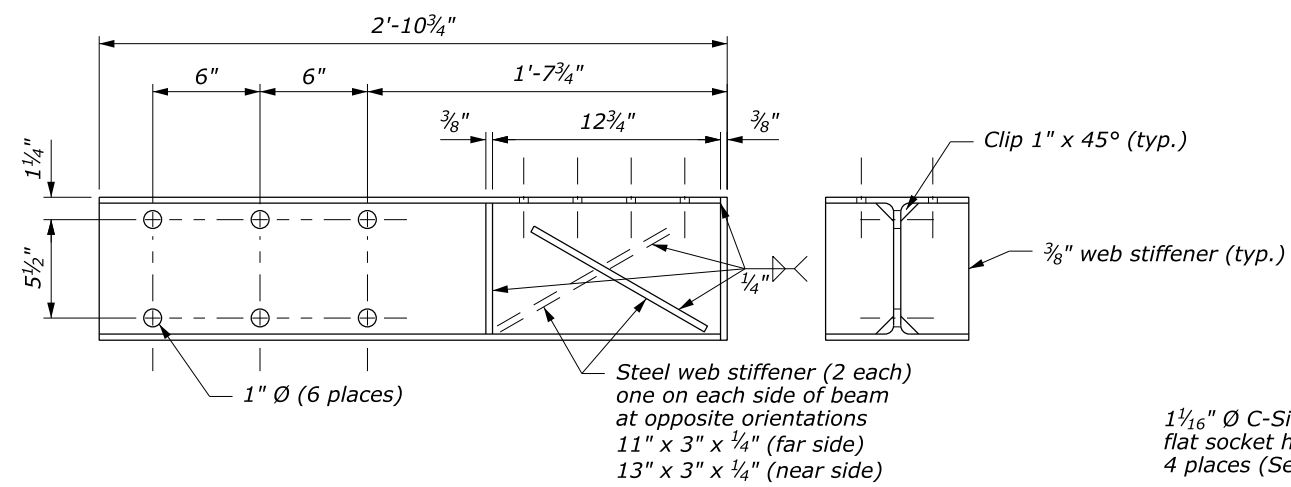

FOUNDATION BEAM

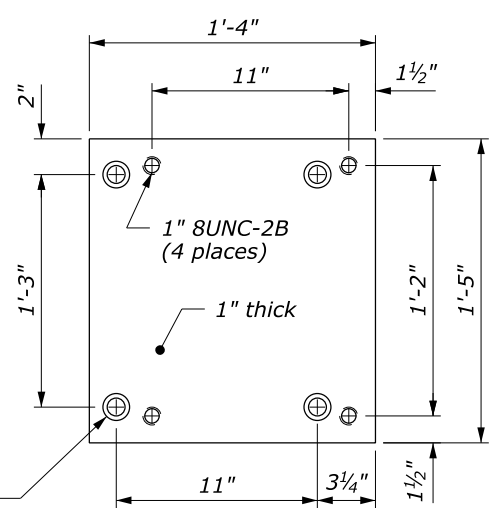

TOP CLAMP PLATE

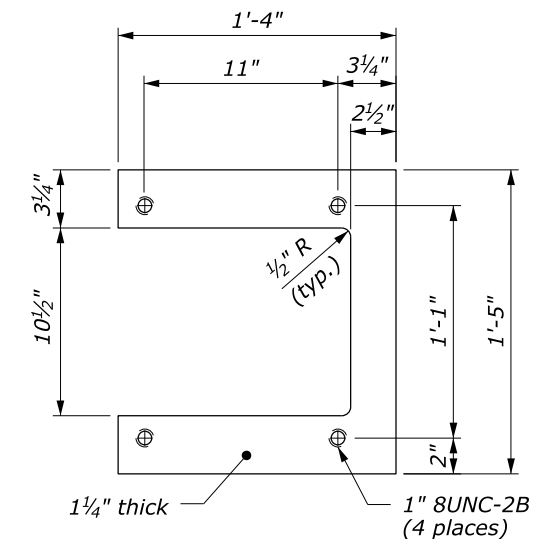

BOTTOM CLAMP PLATE

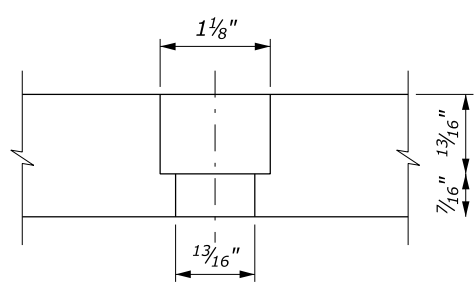

DETAIL A

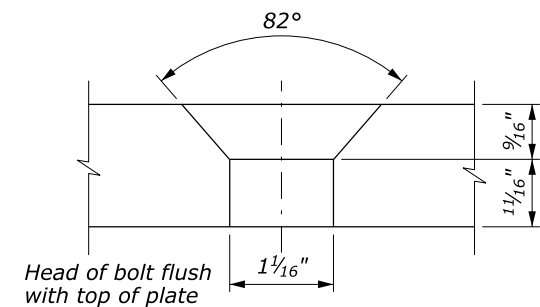

DETAIL B

U.S. DEPARTMENT OF TRANSPORTATION
 FEDERAL HIGHWAY ADMINISTRATION
 WESTERN FEDERAL LANDS HIGHWAY DIVISION

U.S. CUSTOMARY DETAIL
**REMOVABLE
 STEEL-BACKED LOG RAIL**
 Sheet 3 of 3

DETAIL APPROVED FOR USE 3/2009
 REVISIONS:

DETAIL
 W617-83

NO SCALE

18 November 2014 8:42 AM c:\myfiles\pw_production\dms43646\Det-W617-83.dgn [USC]