

**TYPICAL SECTION
RIGHT-OF-WAY MONUMENTATION**

Stamp station, offset and PLS information into cap

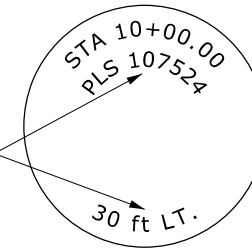

CAP DETAIL

NOTE:

1. *Right-of-Way Witness Post:*
Set a 6 foot long flexible plastic post. Right-of-Way witness posts should be brown, green or other suitable colors to match surroundings. Attach a "Survey Marker Witness" plaque to the post. Station, offset and PLS date of survey should be permanently attached to the front of the post facing the designed alignment.
2. Witness post to be used when Right-of-Way witness post assembly is required.
3. Set monuments using a professional land surveyor according to the requirements of the state code.
4. Station and distances based on Right-of-Way centerline.
5. Install markers so that the center of the cap is not more than 1/2" from the point established.

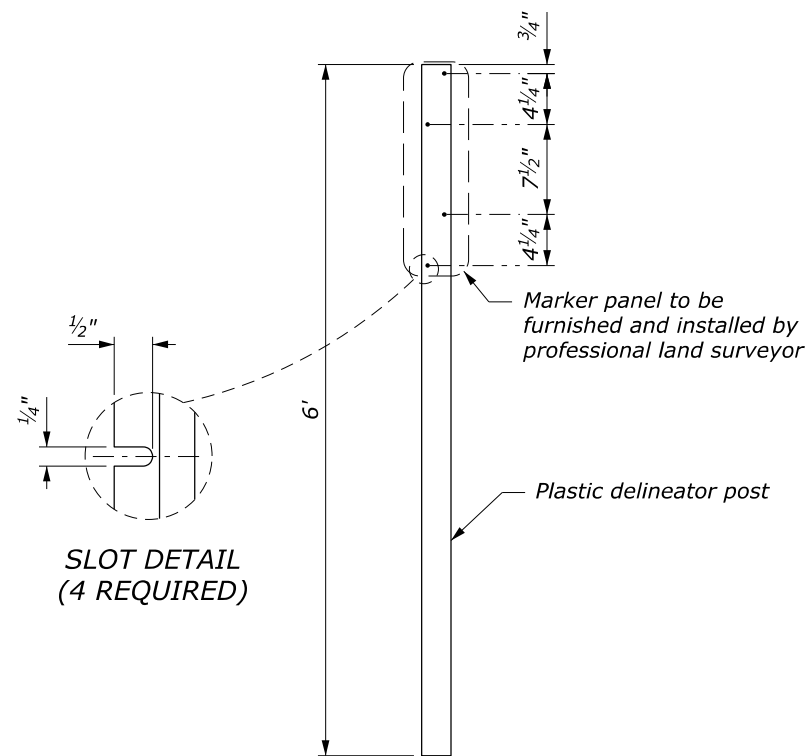

**RIGHT-OF-WAY WITNESS POST
ASSEMBLY DETAIL**

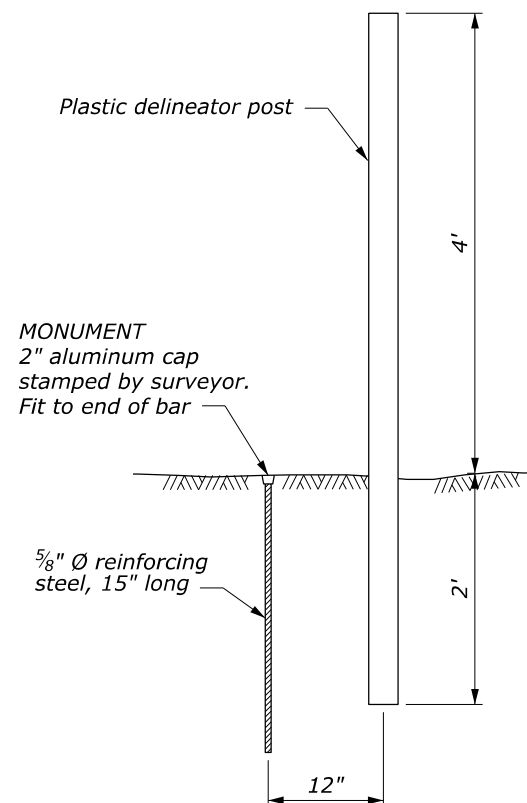

**RIGHT-OF-WAY MONUMENT
AND WITNESS POST
EARTH INSTALLATION**

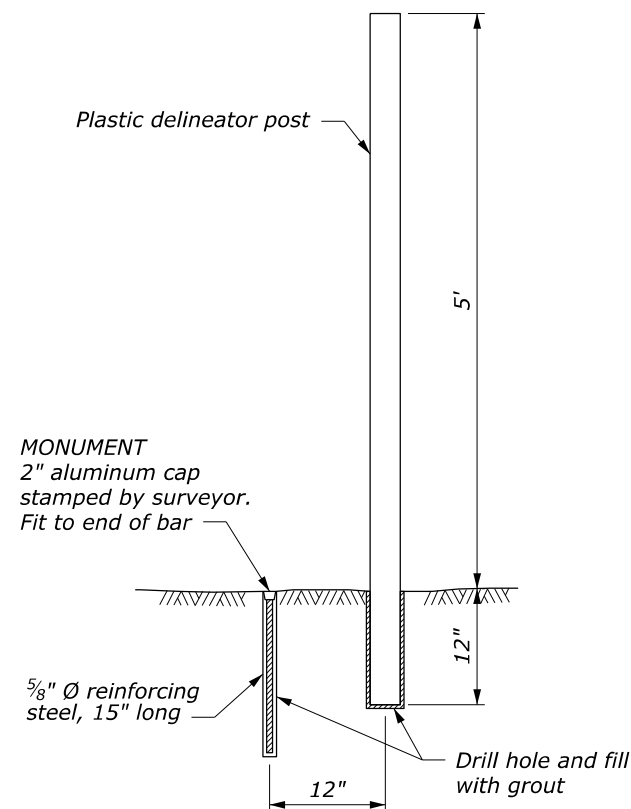

**RIGHT-OF-WAY MONUMENT
AND WITNESS POST
SOLID ROCK INSTALLATION**

NO SCALE

U.S. DEPARTMENT OF TRANSPORTATION FEDERAL HIGHWAY ADMINISTRATION OFFICE OF FEDERAL LANDS HIGHWAY	
WFLHD DETAIL	
RIGHT-OF-WAY MONUMENTATION	
DETAIL APPROVED FOR USE 5/2003 REVISED: 12/2006 11/2007 11/2014	DETAIL W621-1

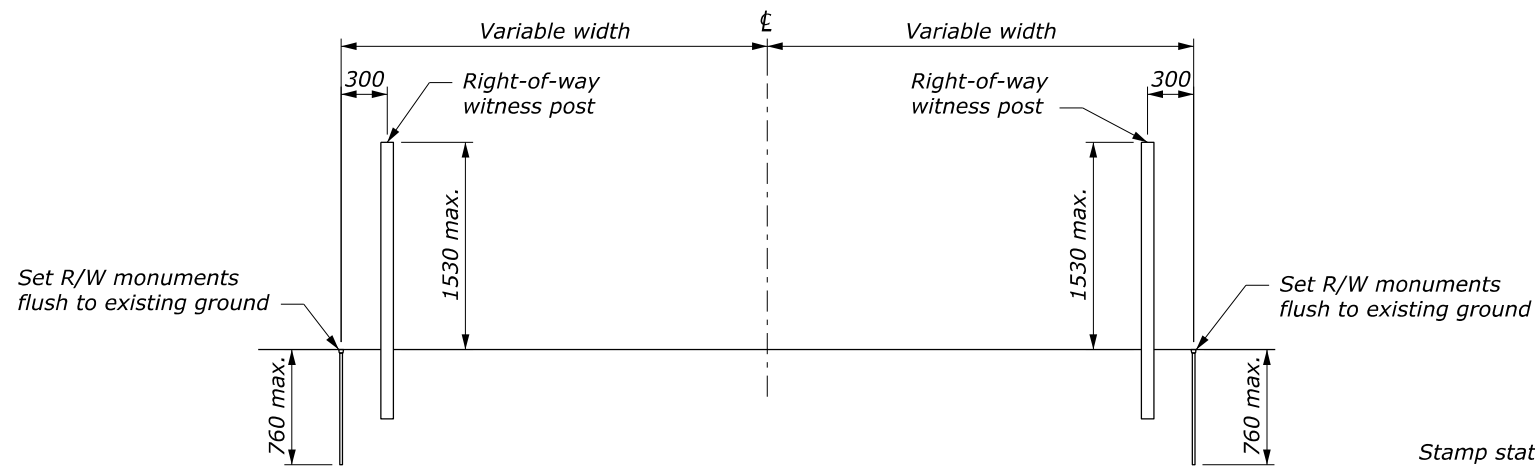

**TYPICAL SECTION
RIGHT-OF-WAY MONUMENTATION**

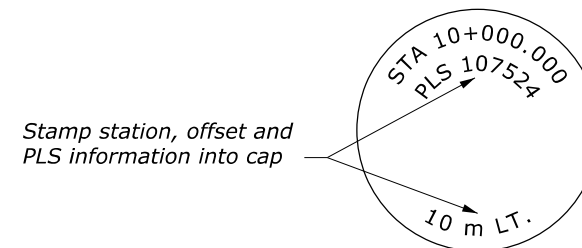

CAP DETAIL

NOTE:

1. **Right-of-Way Witness Post:**
Set a 1830 mm long flexible plastic post. Right-of-Way witness posts should be brown, green or other suitable colors to match surroundings. Attach a "Survey Marker Witness" plaque to the post. Station, offset and PLS date of survey should be permanently attached to the front of the post facing the designed alignment.
2. Witness post to be used when Right-of-Way witness post assembly is required.
3. Set monuments using a professional land surveyor according to the requirements of the state code.
4. Station and distances based on Right-of-Way centerline.
5. Install markers so that the center of the cap is not more than 13 mm from the point established.
6. Dimensions without units are millimeters.

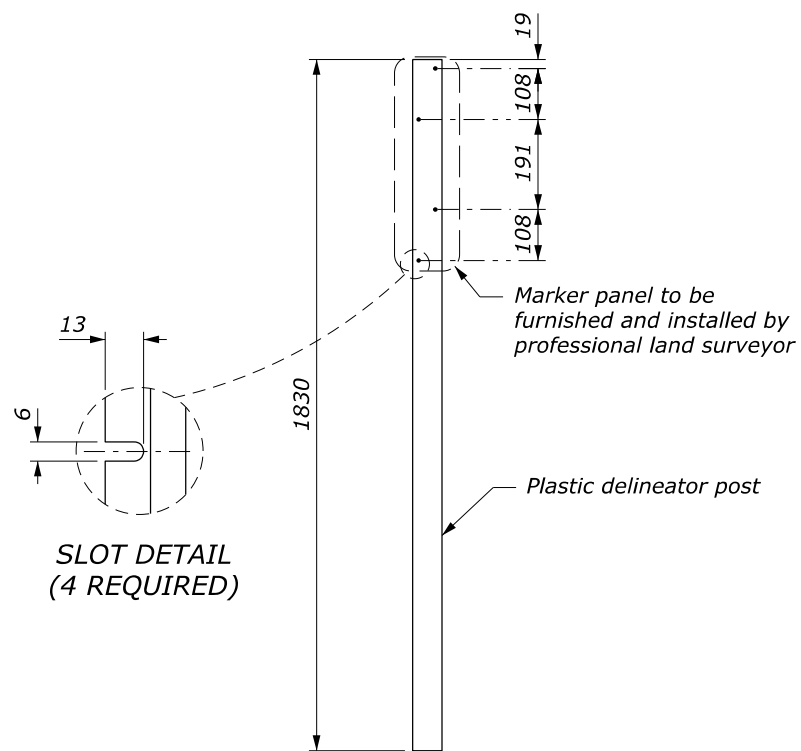

**RIGHT-OF-WAY WITNESS POST
ASSEMBLY DETAIL**

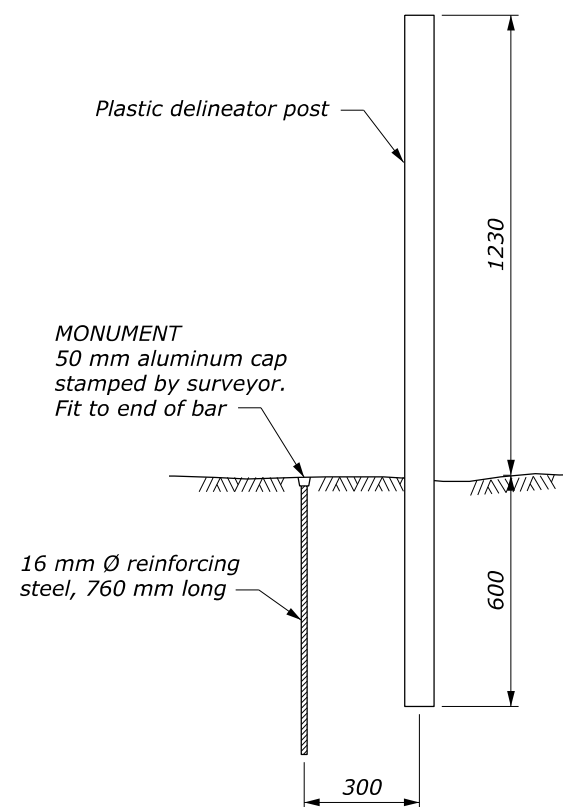

**RIGHT-OF-WAY MONUMENT
AND WITNESS POST
EARTH INSTALLATION**

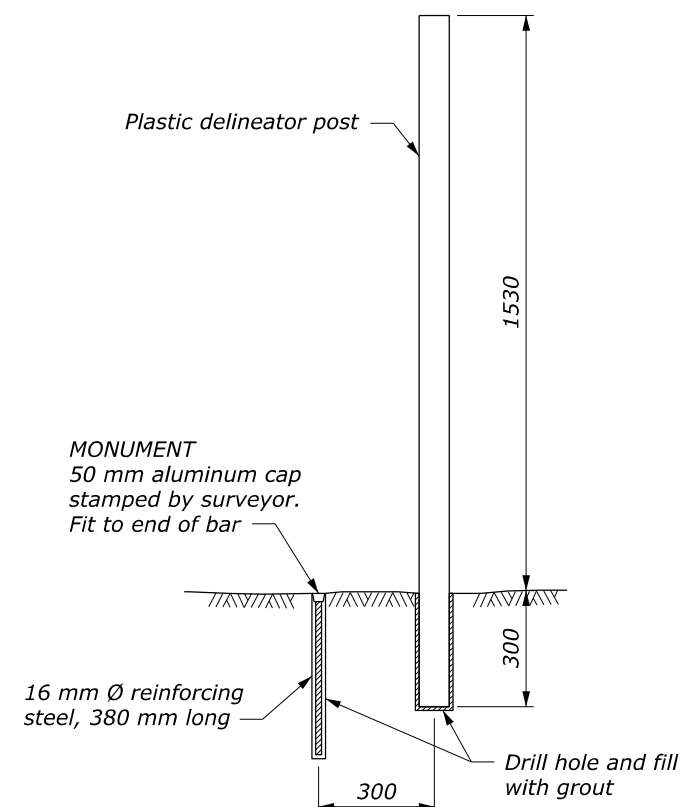

**RIGHT-OF-WAY MONUMENT
AND WITNESS POST
SOLID ROCK INSTALLATION**

NO SCALE

U.S. DEPARTMENT OF TRANSPORTATION FEDERAL HIGHWAY ADMINISTRATION OFFICE OF FEDERAL LANDS HIGHWAY	
WFLHD METRIC DETAIL	
RIGHT-OF-WAY MONUMENTATION	
DETAIL APPROVED FOR USE 5/2003 REVISED: 12/2006 11/2007 11/2014	DETAIL WM621-1

c:\pwwork\0262715\W621-1.dgn [Det: WM621-1] 21 February 2023 9:20 AM