

DESIGN A
(WHITE)

Use for delineation on tangents and on curves with $R > 450$ m.

DESIGN C
(WHITE)

Use on curves with $R \leq 170$ m

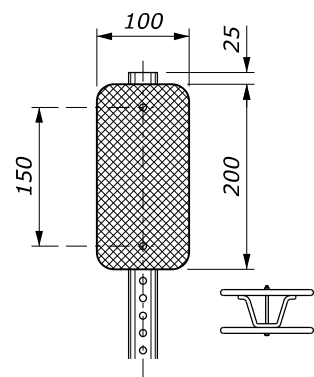

DESIGN D
(YELLOW)

Use at approaches with Stop or Yield signs.

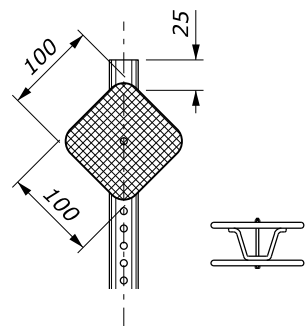

DESIGN F
(WHITE)

Use for curves with $R > 170$ m and $R \leq 450$ m.

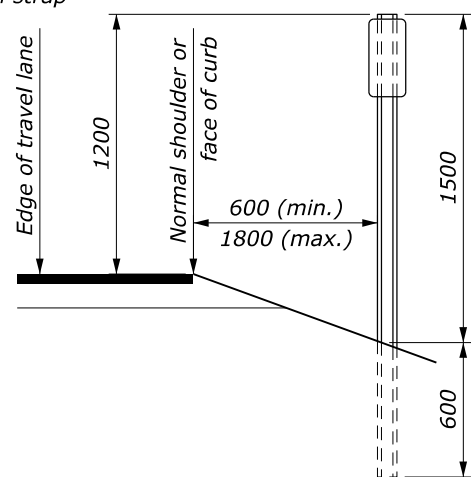

TYPICAL INSTALLATION

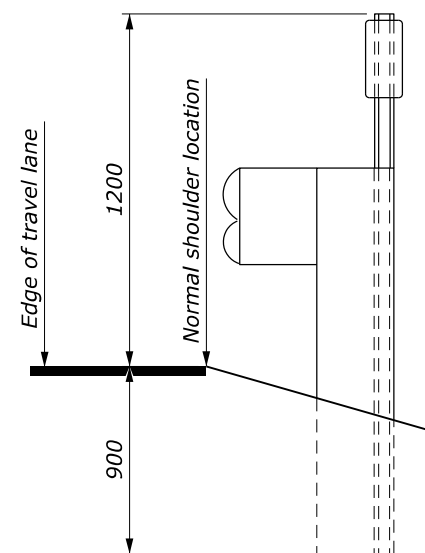

TYPICAL INSTALLATION WITH BEAM TYPE GUARD RAIL

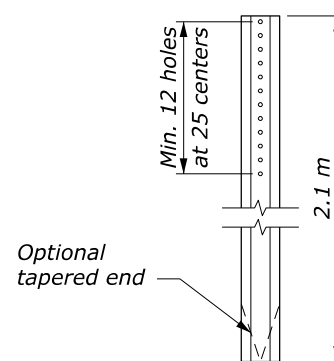

DELINEATOR POST DETAILS

Rigid Steel or Aluminum

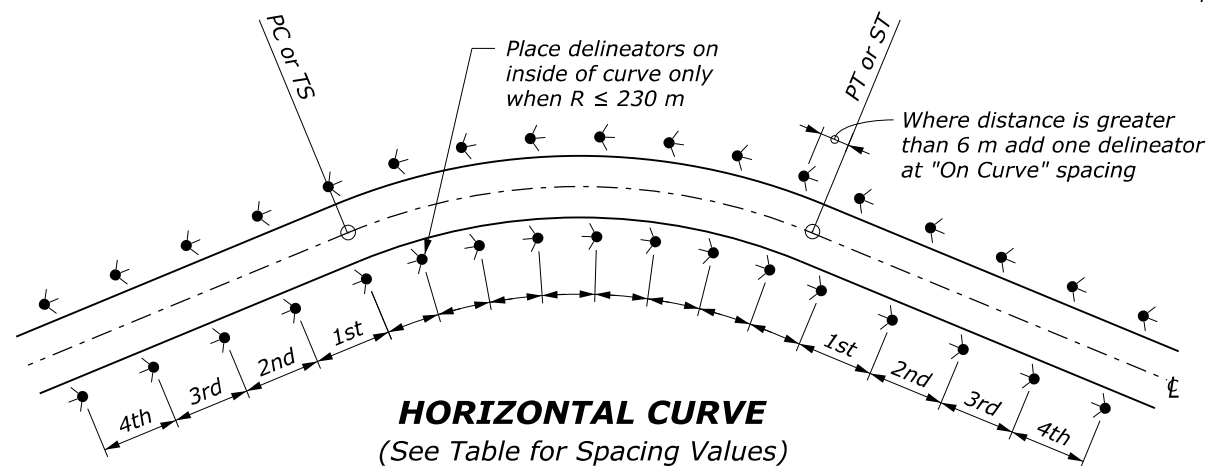
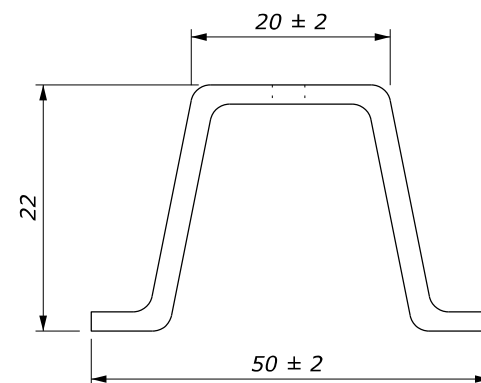

HORIZONTAL CURVE
(See Table for Spacing Values)

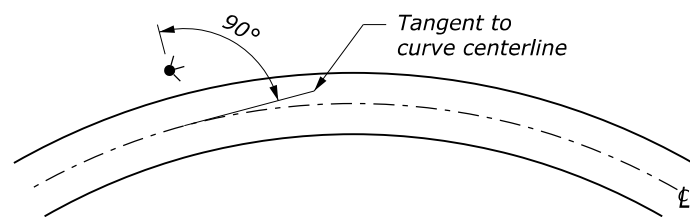

SIGN INSTALLATION ANGLE

HORIZONTAL CURVES					
RADIUS (m)	SPACING ON CURVE (m)	SPACING IN ADVANCE OF & BEYOND CURVE (m)			
		1st SPACE	2nd SPACE	3rd SPACE	4th SPACE
≥ 1750	90	120	120	120	120
900 to < 1750	65	120	120	120	120
600 to < 900	50	95	120	120	120
450 to < 600	40	75	120	120	120
300 to < 450	35	65	100	120	120
200 to < 300	25	55	80	120	120
150 to < 200	20	45	70	90	120
100 to < 150	20	35	55	90	120
< 100	15	25	40	80	120

NOTE:

- When the contract does not include the final surfacing, allow for the thickness of the final pavement structure when establishing the elevation of the traffic delineators.
- Place delineators at a constant clearance distance from the edge of pavement except where guardrail or other obstructions interfere. Align delineators with the inside edge of obstruction. Install delineators located behind beam guardrail so that the delineator post is adjacent to the trailing edge of the nearest guardrail post. (See typical installation with beam type guardrail).
- When a delineator falls within a cross road or approach, the delineator may be moved in either direction a distance not to exceed one quarter of the normal spacing. Eliminate the post if this allowance is exceeded.
- Mount delineators on metal posts with M5 cadmium plated bolt(s). Drill or punch a minimum of twelve 9.5 mm diameter holes on 25 mm centers from the top of the post. 9.5 mm square holes may be used with large-headed bolt or an appropriate washer. Jam threads after tightening the nut to prevent removal.
- All delineator reflectors have 20 mm corner radii.
- Manufacture posts from flanged U-channel sections of steel meeting the requirements of ASTM A 36 and weighing not less than 1.86 kilograms per meter or aluminum meeting the requirements of ASTM B 221, Alloy 6061-T6, with a minimum thickness of 3.2 mm. After fabrication galvanize steel posts in accordance with ASTM A 123.
- When a route has a current ADT of 900 or greater, continuously delineate the roadway along the shoulder by means of post mounted reflectors. Spacing on tangent sections is 120 meters.
- Furnish hardware in the metric sizes shown. Equivalent US Customary sizes may be used when metric sizes are not available.
- Dimensions without units are millimeters.

NO SCALE

U.S. DEPARTMENT OF TRANSPORTATION
FEDERAL HIGHWAY ADMINISTRATION
OFFICE OF FEDERAL LANDS HIGHWAY

WFLHD METRIC DETAIL

MONTANA
DELINEATORS

DETAIL APPROVED FOR USE 11/2006
REVISED: 1/2008

DETAIL
WM633-60