

**SINGLE MAILBOX INSTALLATION**

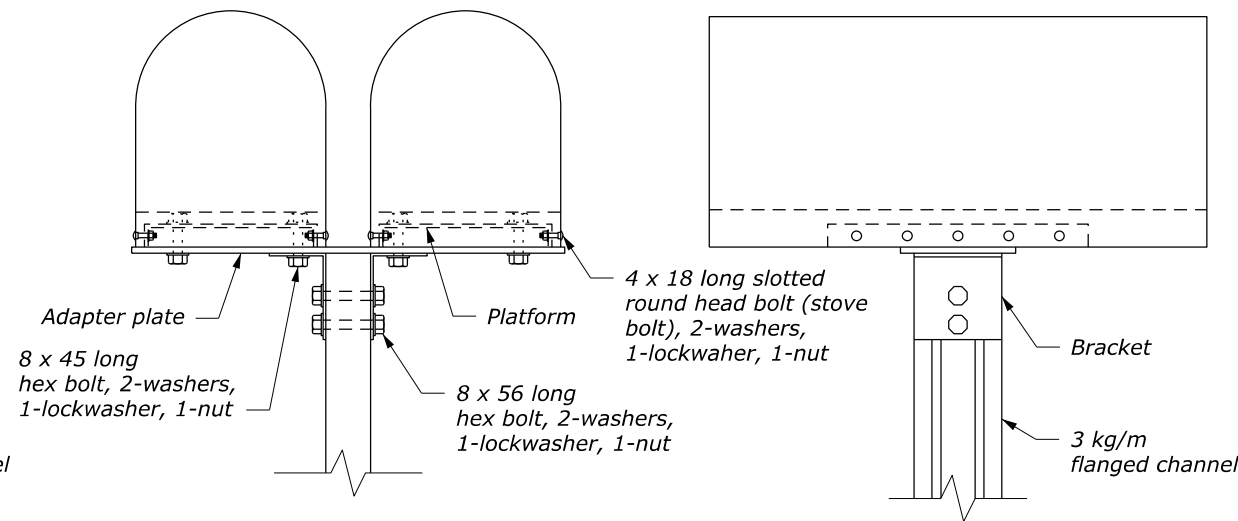

**DOUBLE MAILBOX INSTALLATION**

**NOTE:**  
 1. Spacing between multiple mailboxes and height of mailbox above ground level are as established by the U.S. Postal Service. H is usually 1.0 m to 1.2 m.  
 2. Dimensions without units are millimeters.

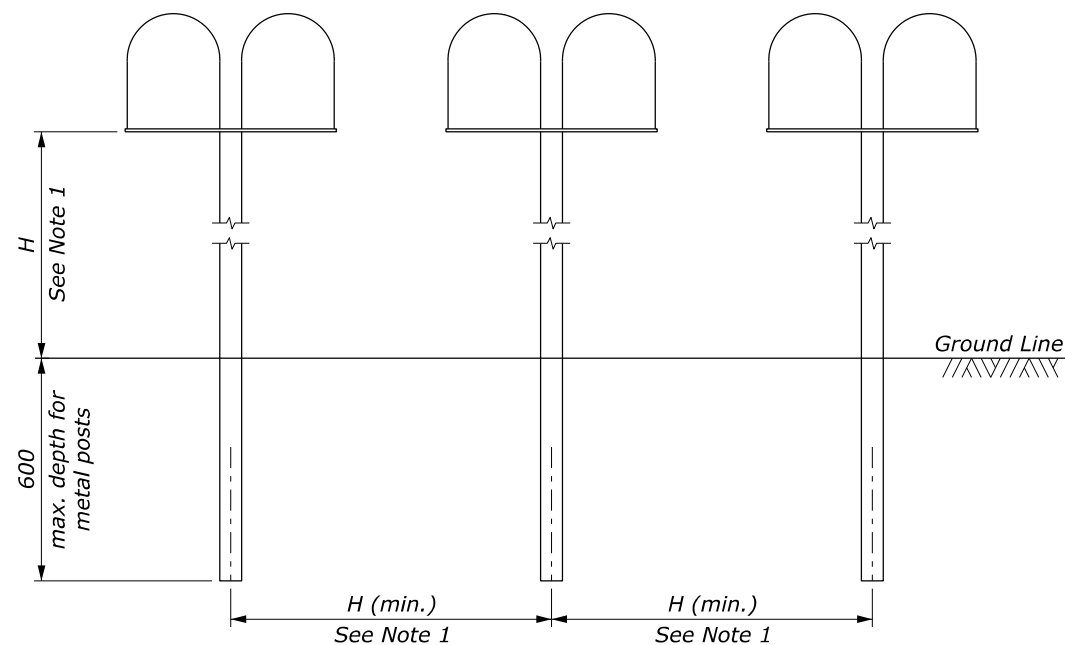

**SPACING FOR MULTIPLE INSTALLATION**

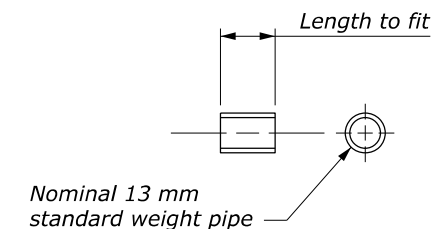

**SPACER**

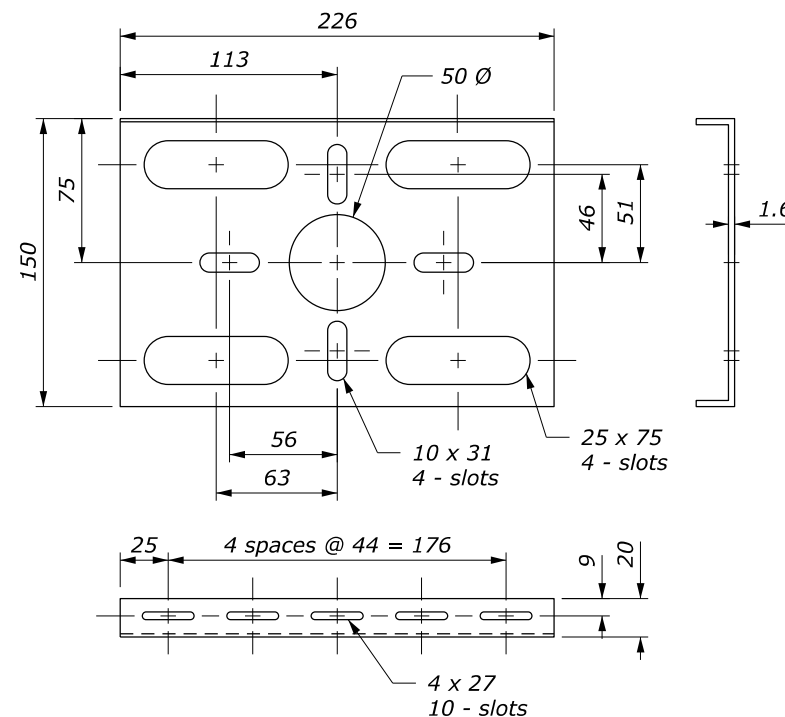

**PLATFORM**

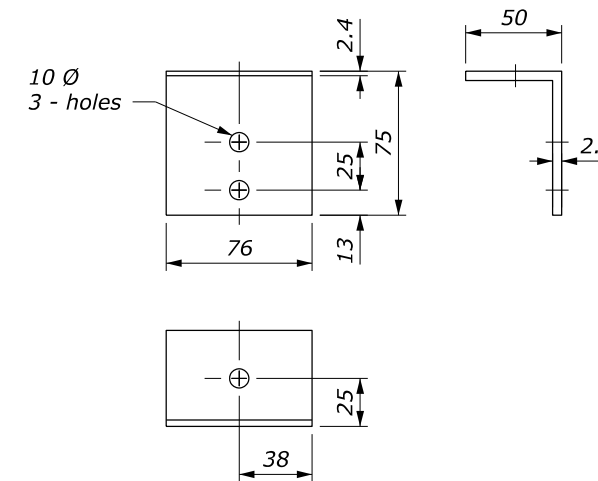

**BRACKET**

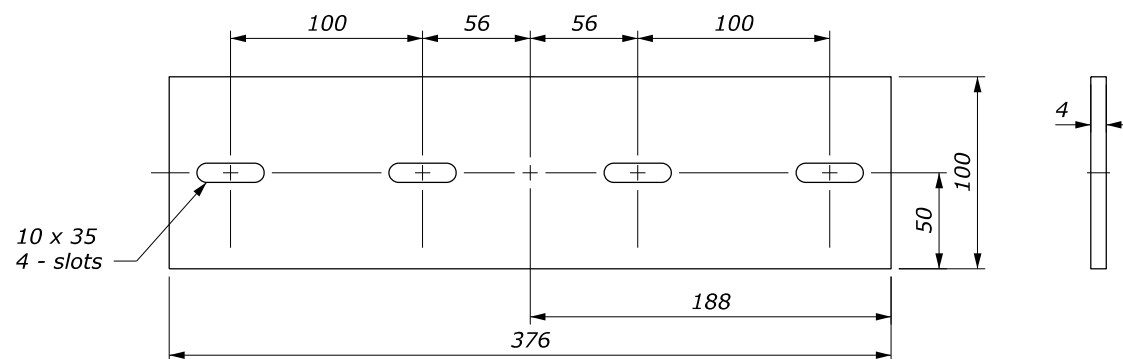

**ADAPTER PLATE**

NO SCALE

U.S. DEPARTMENT OF TRANSPORTATION FEDERAL HIGHWAY ADMINISTRATION OFFICE OF FEDERAL LANDS HIGHWAY	
WFLHD METRIC DETAIL	
<b>MAILBOX ASSEMBLY SERIES B</b>	
DETAIL APPROVED FOR USE 11/2014	DETAIL
REVISED:	WM646-3