

**NOTE:**

1. See Erosion Control Section for temporary culvert diameter, riprap class, channel dimensions and quantities.
2. Use plastic liner or riprap along the entire length and width of the temporary diversion channel.
3. Construct channel at a minimum grade of 0.5 percent.
4. Do not construct with longitudinal joints if using a plastic liner. Bury the upstream edge of the liner a minimum of 6" deep and secure with riprap or sandbags.
5. When specified replace the portion of the diversion channel through the roadway embankment with temporary culvert. Compact temporary culvert backfill using one of the methods listed in Subsection 204.11(a).

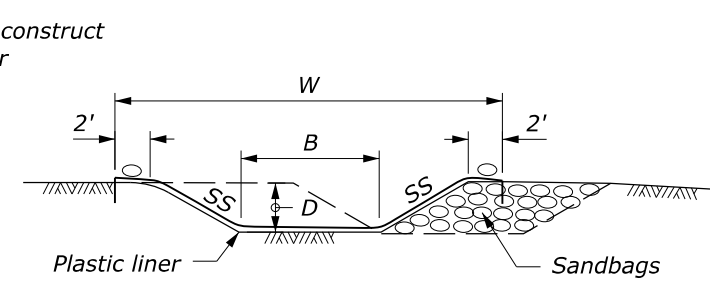

SECTION A-A

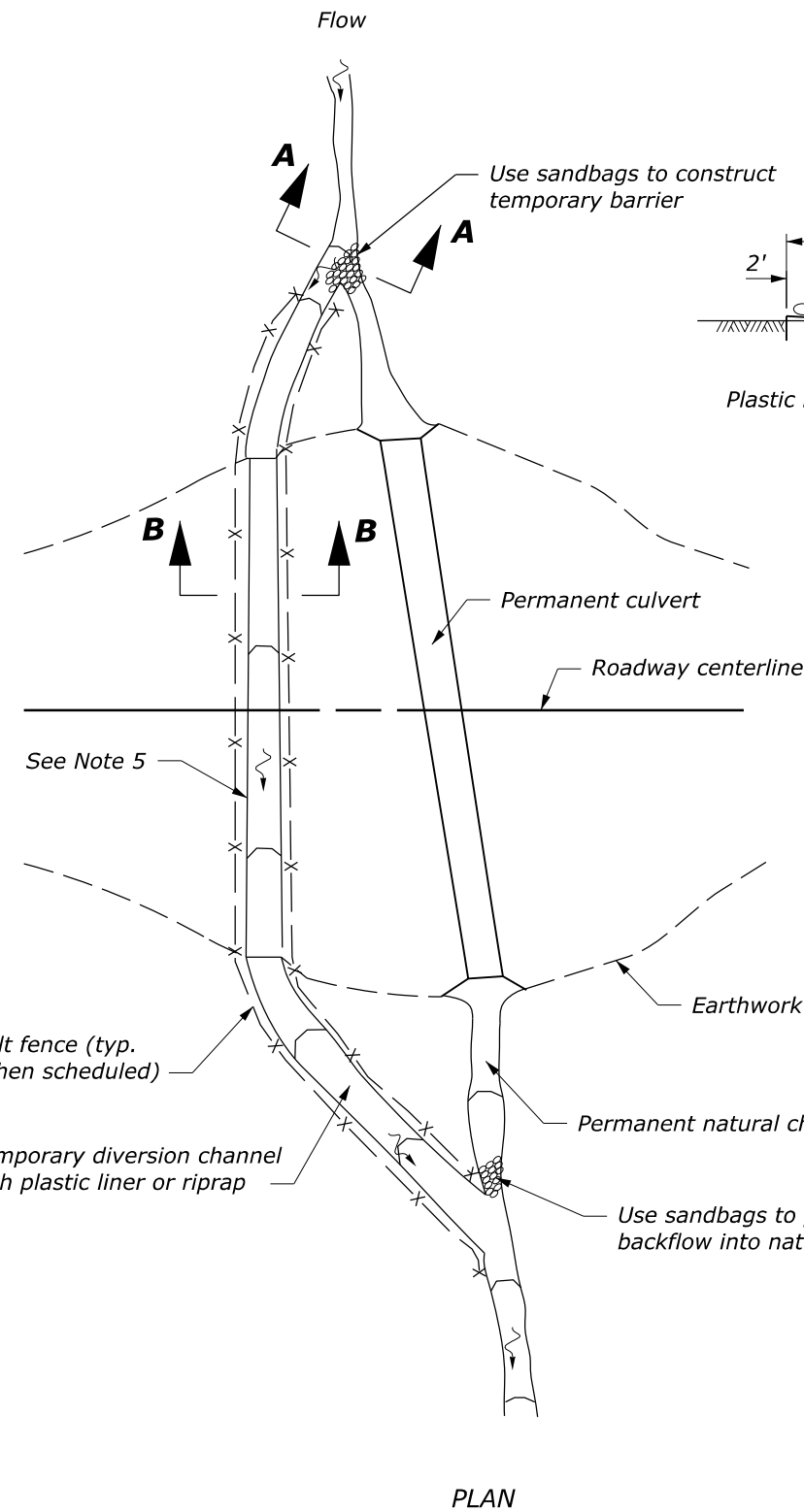
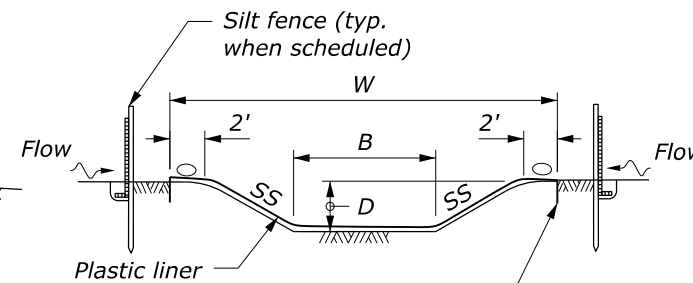

SECTION B-B

**PLASTIC LINED DIVERSION CHANNEL**

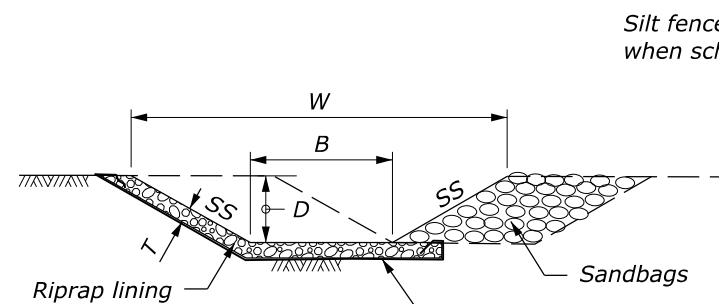

SECTION A-A

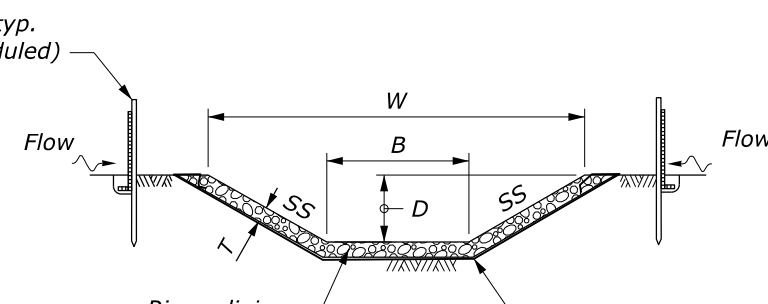

SECTION B-B

**RIPRAP LINED DIVERSION CHANNEL**

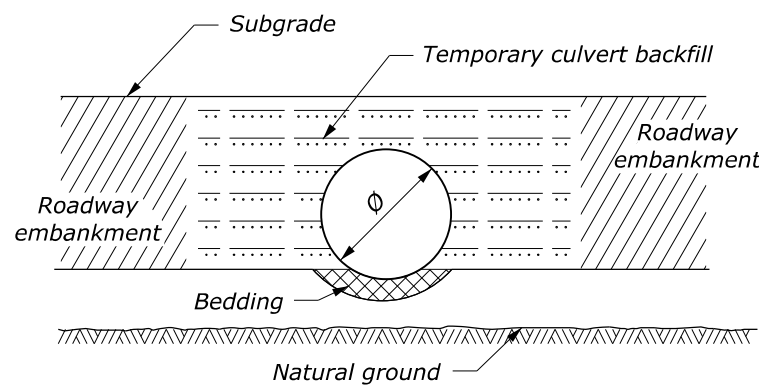

**TEMPORARY CULVERT**

**DIVERSION CHANNEL**

NO SCALE

U.S. DEPARTMENT OF TRANSPORTATION FEDERAL HIGHWAY ADMINISTRATION OFFICE OF FEDERAL LANDS HIGHWAY	
FLH STANDARD	
<b>TEMPORARY DIVERSION CHANNELS</b>	
STANDARD APPROVED FOR USE 6/2005 REVISED: 6/2007 7/2022	STANDARD 157-5