

CONTRACTION JOINT
UNDOWELED - TRANSVERSE and
UNTIED - LONGITUDINAL

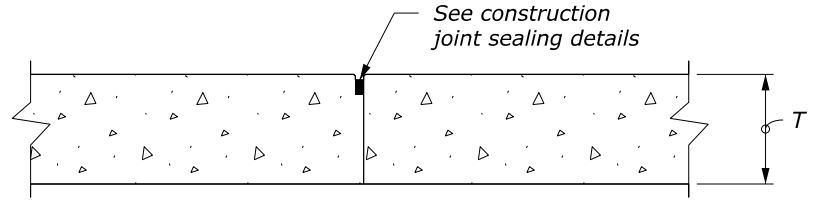

CONSTRUCTION JOINT
PLAIN - TRANSVERSE or LONGITUDINAL

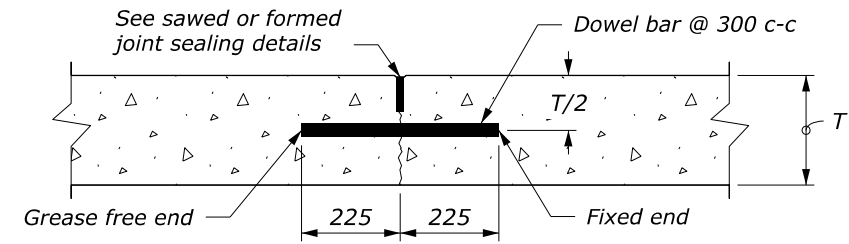

CONTRACTION JOINT
DOWELED - TRANSVERSE

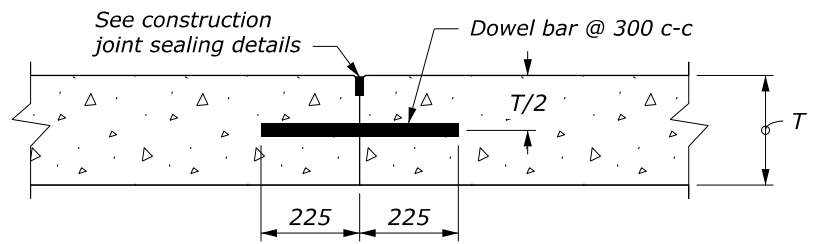

CONSTRUCTION JOINT
DOWEL BUTT - TRANSVERSE

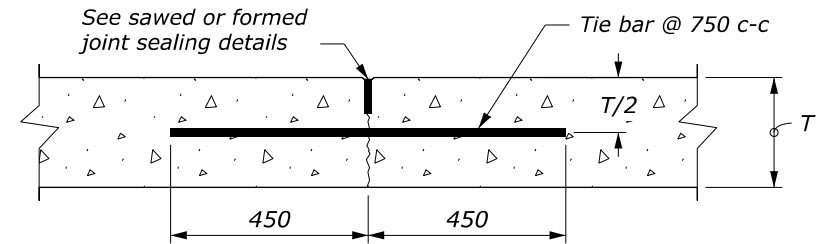

CONTRACTION JOINT
TIED - LONGITUDINAL

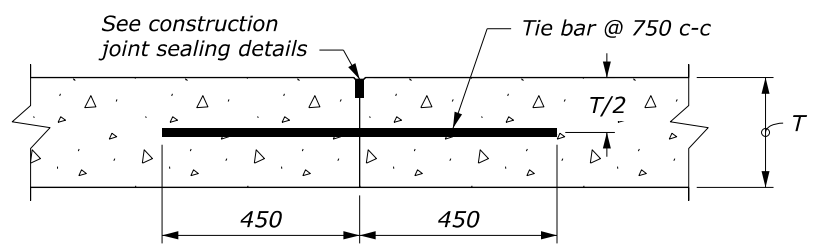

CONSTRUCTION JOINT
TIED BUTT - LONGITUDINAL

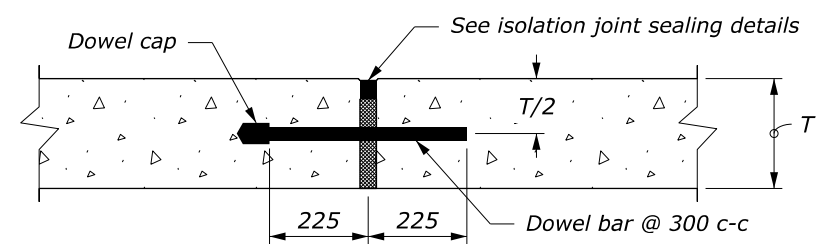

ISOLATION/EXPANSION JOINT
DOWELED - TRANSVERSE

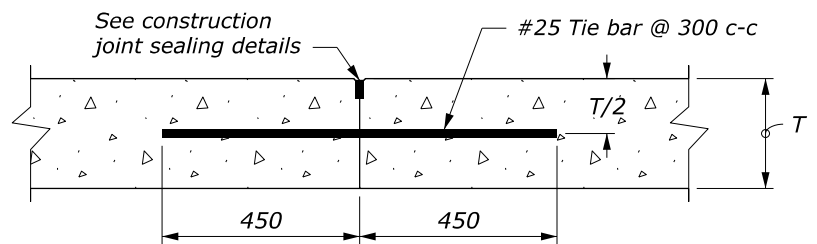

CONSTRUCTION JOINT
TIED BUTT - TRANSVERSE

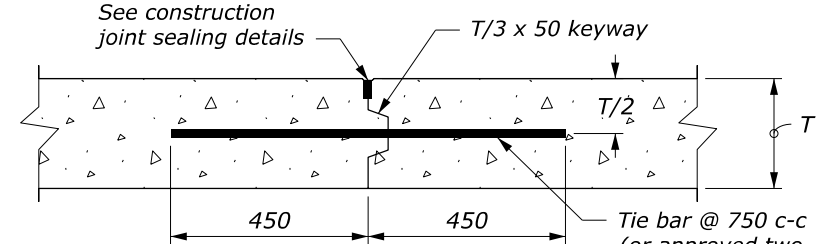

CONSTRUCTION JOINT
KEYWAY - LONGITUDINAL

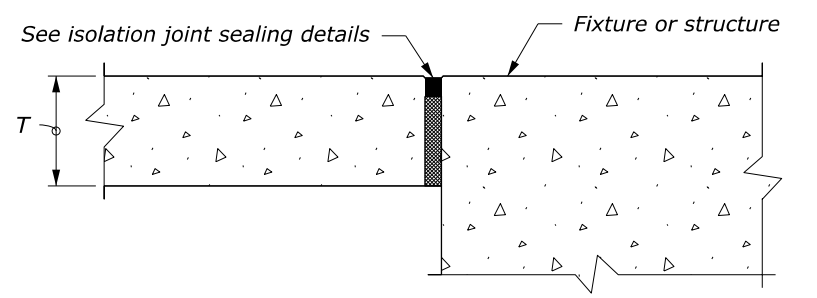

ISOLATION JOINT
UNDOWELED - LONGITUDINAL

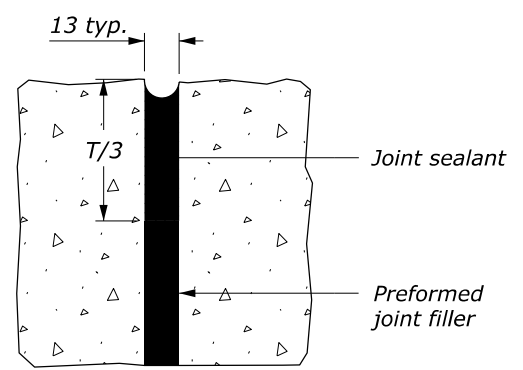

ISOLATION JOINT

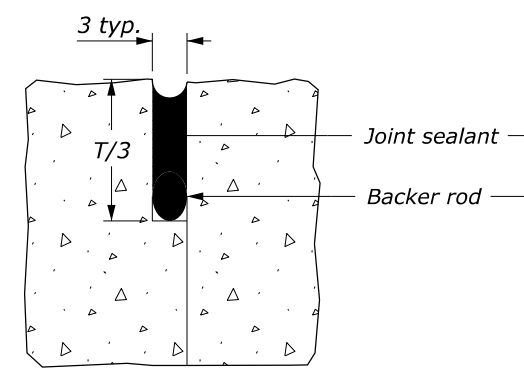

CONSTRUCTION JOINT

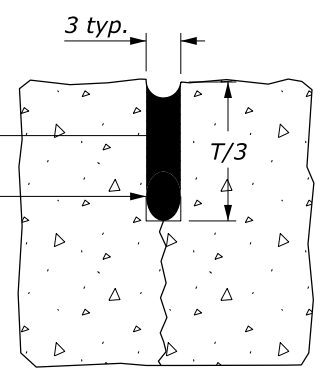

SAWED OR FORMED JOINT

MINOR CONCRETE PAVEMENT JOINT SEALING DETAILS

- NOTE:**
1. Use epoxy-coated material for all tie bars, dowels, and other steel used in the construction of concrete pavement.
 2. Deformed reinforcing bars or hook bolts may be used for tie bars.
 3. Do not place tie bars within 380 mm of transverse joints.
 4. Install isolation joints when abutting a fixed structure. Use expansion joint material extending the full depth and length of the concrete surface.
 5. Transverse and longitudinal construction joints are not included in the joint layout plan. Use transverse and longitudinal construction joints sparingly. Submit planned construction joint locations for approval.
 6. For construction joints, if tie bars and dowels are not set into concrete during placement, drill and anchor the tie bars and dowels into the existing concrete construction with epoxy resin.
 7. Maintain joint sealant shape factor of 1:1; except when silicone sealant is used maintain the width to depth shape factor of 2:1 or as recommended by sealant manufacturer.
 8. See Section 712 for joint material requirements.
 9. See Standards M501-1 or M502-1 for reinforcement details.
 10. Dimensions without units are millimeters.

BAR SIZES		
PAVEMENT THICKNESS (T) (mm)	TIE BAR	DOWEL BAR DIAMETER (mm)
T ≤ 200	16	25
200 < T ≤ 250	16	32
250 < T ≤ 300	19	43

U.S. DEPARTMENT OF TRANSPORTATION
FEDERAL HIGHWAY ADMINISTRATION
OFFICE OF FEDERAL LANDS HIGHWAY

METRIC FLH STANDARD

MINOR CONCRETE PAVEMENT JOINTS

STANDARD APPROVED FOR USE 3/1996

REVISED: 6/1997
DRAFT: 9/2016

STANDARD M501-2

NO SCALE