

HEADWALL FOR DOUBLE PIPE CULVERT

DIMENSIONS, REINFORCING STEEL AND CONCRETE TABLE OF QUANTITIES

D INCH	H FEET	SQUARE HEADWALL					15° SKEW					30° SKEW					45° SKEW				
		A FEET	B FEET	L FEET	CONC. CUYD	STEEL LB	A FEET	B FEET	L FEET	CONC. CUYD	STEEL LB	A FEET	B FEET	L FEET	CONC. CUYD	STEEL LB	A FEET	B FEET	L FEET	CONC. CUYD	STEEL LB
48	5.00	4.00	6.00	14.00	2.13	180	4.25	6.25	14.75	2.25	191	4.50	7.00	16.00	2.43	203	5.75	8.50	20.00	3.05	257
54	5.25	4.75	6.75	16.25	2.57	210	4.75	7.00	16.50	2.60	217	5.25	7.75	18.25	2.87	239	6.50	9.50	22.50	3.54	295
60	5.50	5.25	7.50	18.00	2.94	236	5.50	7.75	18.75	3.07	248	6.00	8.75	20.75	3.39	279	7.50	10.50	25.50	4.17	336
66	5.75	6.00	8.25	20.25	3.43	289	6.00	8.50	20.50	3.45	290	6.75	9.50	23.00	3.88	327	8.25	11.75	28.25	4.77	407
72	6.00	6.50	9.00	22.00	3.84	318	6.75	9.25	22.75	3.97	331	7.50	10.50	25.50	4.46	368	9.25	12.75	31.25	5.46	457
78	6.25	7.25	9.75	24.25	4.38	361	7.50	10.00	25.00	4.51	374	8.25	11.25	27.75	5.00	410	10.00	13.75	33.75	6.07	498
84	6.50	7.75	10.50	26.00	4.83	410	8.00	10.75	26.75	4.96	424	9.00	12.00	30.00	5.58	476	11.00	14.75	36.75	6.83	586
90	6.75	8.50	11.25	28.25	5.43	458	8.75	11.75	29.25	5.62	475	9.75	13.00	32.50	6.24	526	11.75	16.00	39.50	7.56	638
96	7.00	9.00	12.00	30.00	5.92	491	9.25	12.50	31.00	6.11	509	10.50	13.75	34.75	6.86	575	12.75	17.00	42.50	8.39	699
102	7.25	9.75	12.50	32.00	6.49	553	10.00	13.00	33.00	6.69	571	11.00	14.50	36.50	7.37	637	13.50	17.75	44.75	9.04	783
108	7.50	10.25	13.00	33.50	6.95	591	10.50	13.50	34.50	7.14	604	11.75	15.00	38.50	7.97	676	14.50	18.50	47.50	9.86	842
114	7.75	11.00	13.50	35.50	7.56	632	11.25	14.00	36.50	7.76	654	12.50	15.50	40.50	8.59	717	15.50	19.00	50.00	10.64	893
120	8.00	11.50	14.00	37.00	8.05	666	12.00	14.50	38.50	8.40	695	13.25	16.25	42.75	9.31	771	16.25	19.75	52.25	11.37	949
126	8.25	12.25	14.50	39.00	8.71	748	12.50	15.00	40.00	8.90	760	14.00	16.75	44.75	9.97	858	17.25	20.50	55.00	12.27	1053
132	8.50	12.75	15.00	40.50	9.23	775	13.25	15.50	42.00	9.58	805	14.75	17.25	46.75	10.65	902	18.00	21.25	57.25	13.05	1105
138	8.75	13.50	15.50	42.50	9.93	831	13.75	16.00	43.50	10.11	842	15.50	18.00	49.00	11.44	955	19.00	22.00	60.00	14.00	1173
144	9.00	14.00	16.00	44.00	10.48	902	14.50	16.50	45.50	10.83	922	16.25	18.50	51.00	12.16	1039	19.75	22.75	62.25	14.83	1281
150	9.25	14.75	16.50	46.00	11.21	950	15.25	17.00	47.50	11.57	981	17.00	19.00	53.00	12.91	1087	20.75	23.25	64.75	15.76	1341
156	9.50	15.25	17.00	47.50	11.80	991	15.75	17.50	49.00	12.15	1022	17.50	19.75	54.75	13.59	1144	21.50	24.00	67.00	16.62	1394
162	9.75	16.00	17.50	49.50	12.57	1077	16.50	18.00	51.00	12.93	1109	18.25	20.25	56.75	14.37	1236	22.50	24.75	69.75	17.69	1533
168	10.00	16.50	18.00	51.00	13.19	1121	17.00	18.75	52.75	13.63	1157	19.00	20.75	58.75	15.18	1288	23.25	25.50	72.00	18.60	1581
174	10.25	17.25	18.50	53.00	14.00	1173	17.75	19.25	54.75	14.45	1222	19.75	21.25	60.75	16.00	1353	24.25	26.25	74.75	19.73	1673
180	10.50	17.75	19.00	54.50	14.65	1218	18.50	19.75	56.75	15.29	1276	20.50	22.00	63.00	16.94	1411	25.00	26.75	76.75	20.59	1727

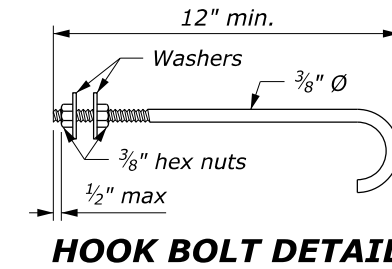

HOOK BOLT DETAIL

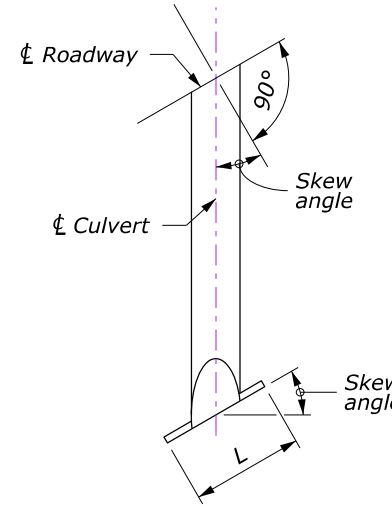

TYPICAL HALF PLAN

NOTE:

- Concrete conforms to Section 601. Pour concrete monolithically. Chamfer all exposed edges 3/4" and finish all exposed surfaces with a Class 1 ordinary finish.
- Clearance for reinforcing steel is 2" unless otherwise noted.
- Headwall dimension "H" may be reduced in solid rock provided the wall is keyed into the rock at least 1 foot. Excavate and backfill according to Section 209.
- Set hook bolts on nominal 18" centers around pipe pipe perimeter at center of headwall. Hook bolts conform to ASTM A307. Galvanize according to ASTM A153.
- For installations with more than two pipe culverts, increase the dimension "L" and all quantities shown for double pipe installation by adding a length equal to dimension "B" and the incremental change in quantities for each additional pipe culvert.
- For skews other than those shown, multiply quantities and dimensions "A", "B" & "L" for square headwalls by secant of the skew angle.
- Final quantities will be determined by using the tables on this standard.
- Do not order materials until the length, skew angle, and slope bevel in the field have been approved.

HEADWALL FOR SINGLE PIPE CULVERT

DIMENSIONS, REINFORCING STEEL AND CONCRETE TABLE OF QUANTITIES

D INCH	H FEET	SQUARE HEADWALL			15° SKEW			30° SKEW			45° SKEW		
		L FEET	CONC. CUYD	STEEL LB	L FEET	CONC. CUYD	STEEL LB	L FEET	CONC. CUYD	STEEL LB	L FEET	CONC. CUYD	STEEL LB
48	5.00	8.00	1.25	101	8.25	1.29	109	9.25	1.44	120	11.25	1.75	144
54	5.25	9.25	1.50	124	9.50	1.54	126	10.75	1.75	148	13.00	2.11	175
60	5.50	10.50	1.78	143	10.75	1.81	151	12.00	2.02	164	14.75	2.49	208
66	5.75	11.75	2.06	175	12.25	2.15	186	13.50	2.37	203	16.50	2.89	249
72	6.00	13.00	2.37	196	13.50	2.46	207	15.00	2.73	231	18.50	3.37	286
78	6.25	14.25	2.68	221	14.75	2.78	233	16.50	3.11	259	20.25	3.82	317
84	6.50	15.50	3.02	256	16.00	3.11	268	18.00	3.51	299	22.00	4.29	368
90	6.75	16.75	3.37	284	17.25	3.47	297	19.25	3.87	327	23.75	4.78	406
96	7.00	18.00	3.74	309	18.75	3.90	325	20.75	4.30	364	25.50	5.29	442
102	7.25	19.25	4.12	354	20.00	4.28	371	22.25	4.76	416	27.25	5.83	510
108	7.50	20.50	4.52	381	21.25	4.68	399	23.75	5.24	447	29.00	6.39	554
114	7.75	21.75	4.93	419	22.50	5.10	430	25.00	5.66	479	30.75	6.97	594
120	8.00	23.00	5.36	441	23.75	5.53	460	26.50	6.17	521	32.50	7.57	634
126	8.25	24.25	5.81	502	25.00	5.98	514	28.00	6.70	572	34.25	8.20	711
132	8.50	25.50	6.27	527	26.50	6.52	560	29.50	7.25	618	36.00	8.84	754
138	8.75	26.75	6.75	570	27.75	7.00	584	31.00	7.83	658	37.75	9.51	799
144	9.00	28.00	7.24	619	29.00	7.50	654	32.25	8.33	723	39.50	10.20	885
150	9.25	29.25	7.75	665	30.25	8.01	680	33.75	8.94	761	41.25	10.92	933
156	9.50	30.50	8.27	692	31.50	8.54	728	35.25	9.56	805	43.25	11.74	996
162	9.75	31.75	8.81	767	32.75	9.08	783	36.75	10.21	889	45.00	12.50	1094
168	10.00	33.00	9.37	796	34.25	9.73	838	38.00	10.78	919	46.75	13.28	1146
174	10.25	34.25	9.94	847	35.50	10.31	867	39.50	11.46	974	48.50	14.09	1197
180	10.50	35.50	10.53	877	36.75	10.90	920	41.00	12.17	1022	50.25	14.91	1260

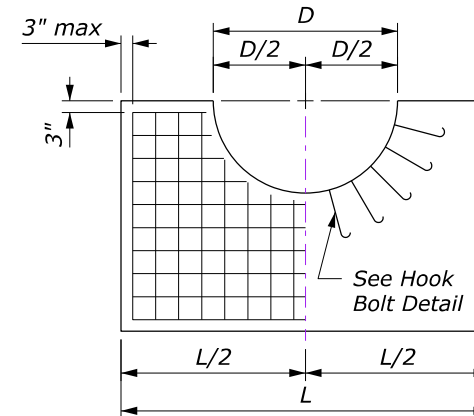

SINGLE PIPE CULVERT

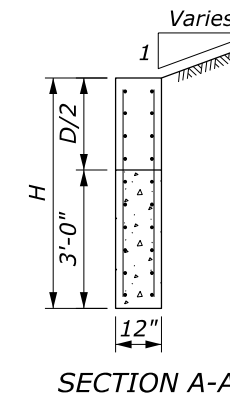

SECTION A-A

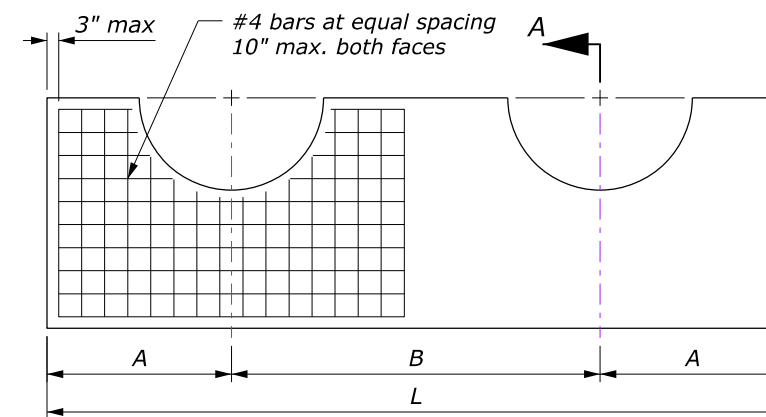

DOUBLE PIPE CULVERT HEADWALLS

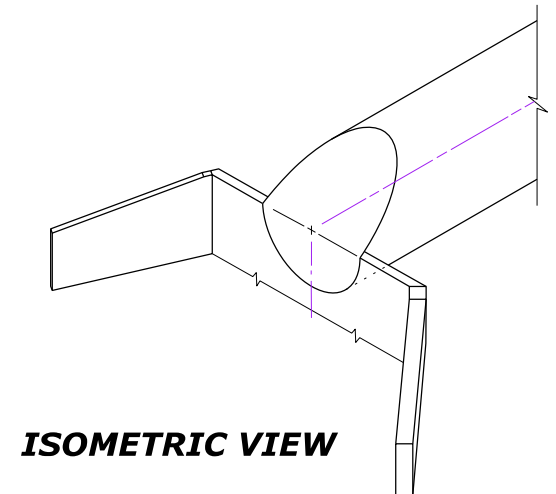

ISOMETRIC VIEW

NO SCALE

U.S. DEPARTMENT OF TRANSPORTATION
FEDERAL HIGHWAY ADMINISTRATION
OFFICE OF FEDERAL LANDS HIGHWAY

FLH STANDARD

CONCRETE HEADWALLS

STANDARD APPROVED FOR USE 6/2005
REVISED: 6/2007

STANDARD
601-1