

WINGWALLS FOR CONCRETE HEADWALLS

DIMENSIONS, REINFORCING STEEL AND CONCRETE TABLE OF QUANTITIES

D INCH	H FEET	0° WINGWALL SKEW			15° WINGWALL SKEW			30° WINGWALL SKEW			45° WINGWALL SKEW			60° WINGWALL SKEW		
		W FEET	CONC. CUYD	STEEL LB	W FEET	CONC. CUYD	STEEL LB	W FEET	CONC. CUYD	STEEL LB	W FEET	CONC. CUYD	STEEL LB	W FEET	CONC. CUYD	STEEL LB
48	5.00	6.00	2.81	178	6.00	2.78	178	6.00	2.76	178	6.00	2.74	178	6.00	2.73	178
54	5.25	6.00	2.86	180	6.00	2.82	180	6.00	2.80	180	6.00	2.78	180	6.75	3.06	202
60	5.50	6.25	2.90	181	6.00	2.86	181	6.00	2.84	181	6.00	2.82	181	7.50	3.39	224
66	5.75	7.00	2.94	183	6.00	2.90	183	6.00	2.87	183	6.00	2.85	183	8.25	3.74	241
72	6.00	7.50	2.98	185	6.00	2.94	185	6.00	2.91	185	6.50	3.09	202	9.00	4.09	263
78	6.25	8.25	3.02	186	6.00	2.98	186	6.00	2.95	186	7.00	3.34	213	9.75	4.45	285
84	6.50	8.75	3.06	188	6.00	3.02	188	6.25	3.09	197	7.50	3.59	232	10.50	4.81	311
90	6.75	9.50	3.11	190	6.00	3.06	190	6.50	3.24	207	8.00	3.84	246	11.25	5.18	329
96	7.00	10.00	3.15	191	6.25	3.21	200	7.00	3.49	218	8.50	4.10	260	12.00	5.56	350

WINGWALL	PIPE SKEW			
	0°	15°	30°	45°
①	45°	45°	60°	60°
②	45°	30°	15°	0°
③	45°	30°	15°	0°
④	45°	45°	60°	60°

NOTE:

- Concrete conforms to Section 601. Chamfer all exposed edges 3/4-inch and finish all exposed surfaces with a Class 1 ordinary finish.
- Reinforcing steel clearance is 2-inches unless otherwise noted.
- For skew angles shown in table, the length W and quantities for wingwalls are computed for a 1V:1.5H side slope. For 1V:2H or 1V:2.5H slopes compute length W with the following equation:
 $W = D/2 \times \text{slope} \times \text{secant (wingwall skew angle)}$
Minimum W not less than 6 feet.
- Quantities shown in table are for one wingwall only. For lengths W not shown in table, approximate the quantities by multiplying the quantities for 0° skew and a given height H by the factor: $1 + [(W-6.0) \times 0.14]$.
- See Standards 601-1 and 601-2 for headwall and slope paving dimensions.
- Final quantities will be determined by using the tables on this standard.
- Do not order materials until the length, skew angle, and slope bevel in the field have been approved.

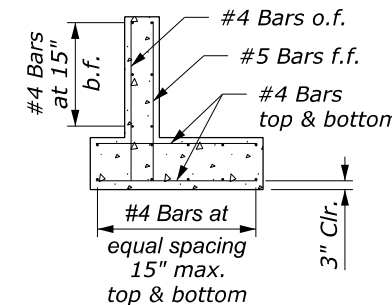

SECTION A-A

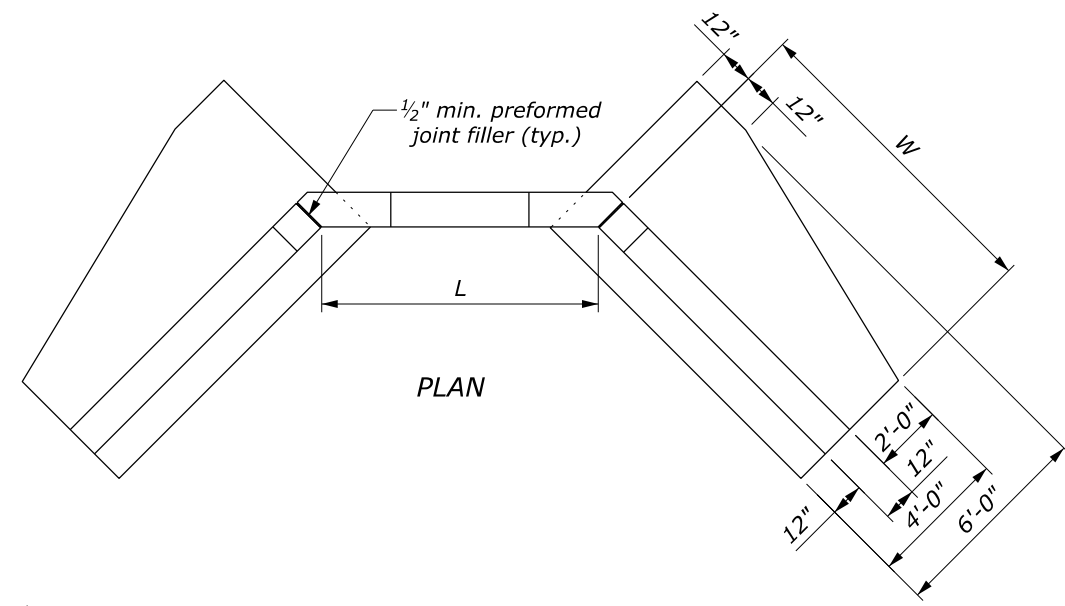

PLAN

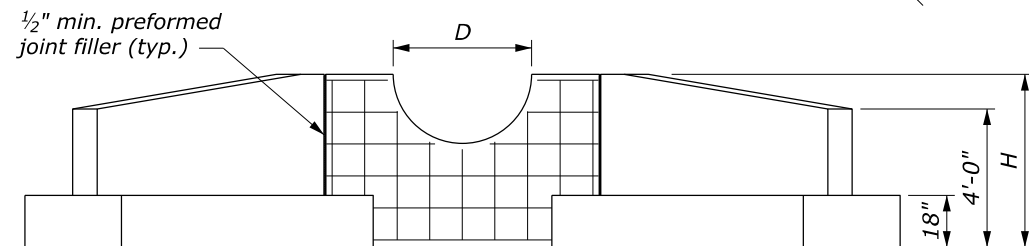

ELEVATION

HEADWALL AND WINGWALL

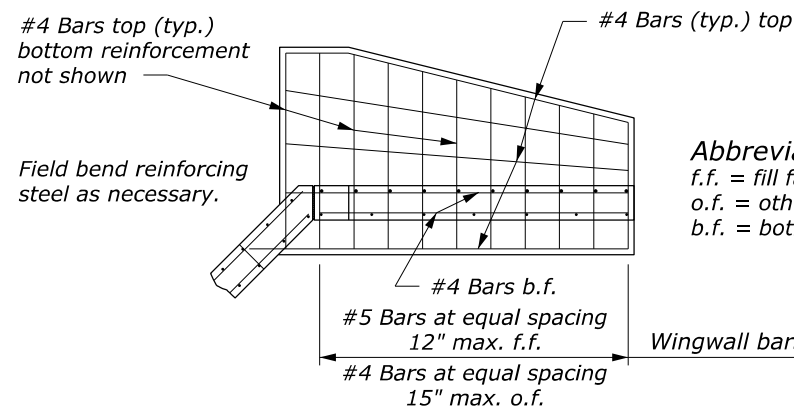

PLAN

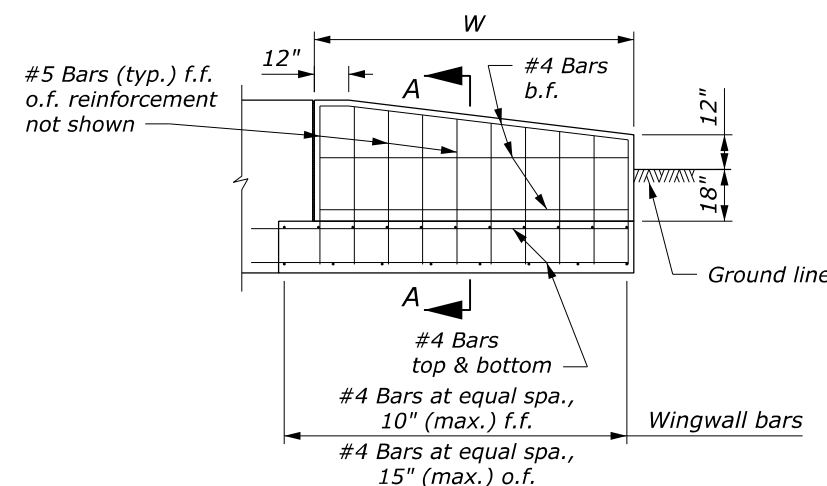

ELEVATION

TYPICAL WINGWALL

Abbreviations:
f.f. = fill face
o.f. = other face
b.f. = both faces

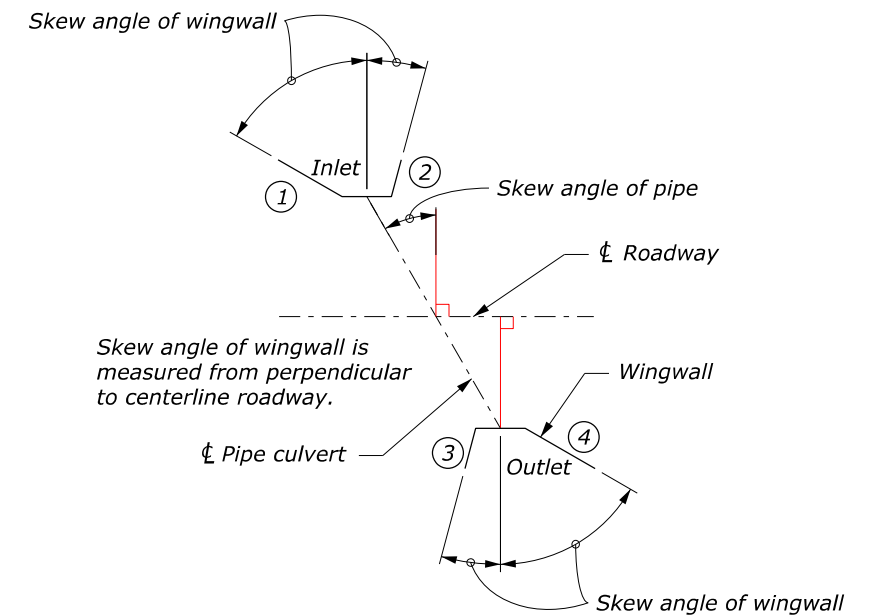

WINGWALL LAYOUT

NO SCALE

U.S. DEPARTMENT OF TRANSPORTATION
FEDERAL HIGHWAY ADMINISTRATION
OFFICE OF FEDERAL LANDS HIGHWAY

FLH STANDARD

**WINGWALLS FOR
CONCRETE HEADWALLS**

STANDARD APPROVED FOR USE 6/2005
REVISED: 6/2007

STANDARD
601-3