

WINGWALLS FOR CONCRETE HEADWALLS

DIMENSIONS, REINFORCING STEEL AND CONCRETE TABLE OF QUANTITIES

D	H m	0° WINGWALL SKEW			15° WINGWALL SKEW			30° WINGWALL SKEW			45° WINGWALL SKEW			60° WINGWALL SKEW		
		W m	CONC. m3	STEEL kg	W m	CONC. m3	STEEL kg	W m	CONC. m3	STEEL kg	W m	CONC. m3	STEEL kg	W m	CONC. m3	STEEL kg
1200	1.500	1.8	2.05	80	1.8	2.03	80	1.8	2.01	80	1.8	2.00	80	1.8	1.99	80
1350	1.575	1.8	2.08	80	1.8	2.06	80	1.8	2.04	80	1.8	2.03	80	2.1	2.30	92
1500	1.650	1.8	2.11	81	1.8	2.09	81	1.8	2.07	81	1.8	2.05	81	2.3	2.52	101
1650	1.725	1.8	2.14	82	1.8	2.12	82	1.8	2.10	82	1.8	2.08	82	2.5	2.75	108
1800	1.800	1.8	2.17	82	1.8	2.15	82	1.8	2.12	82	2.0	2.30	92	2.7	2.98	117
1950	1.875	1.8	2.20	83	1.8	2.17	83	1.8	2.15	83	2.1	2.43	95	3.0	3.32	130
2100	1.950	1.8	2.23	84	1.8	2.20	84	1.9	2.28	88	2.3	2.66	104	3.2	3.56	140
2250	2.025	1.8	2.26	85	1.8	2.23	85	2.0	2.41	95	2.4	2.80	110	3.4	3.80	147
2400	2.100	1.8	2.30	85	1.9	2.36	90	2.1	2.54	97	2.6	3.04	117	3.6	4.05	156

WINGWALL	PIPE SKEW			
	0°	15°	30°	45°
①	45°	45°	60°	60°
②	45°	30°	15°	0°
③	45°	30°	15°	0°
④	45°	45°	60°	60°

NOTE:

- Concrete conforms to Section 601. Chamfer all exposed edges 20 mm and finish all exposed surfaces with a Class 1 ordinary finish.
- Reinforcing steel clearance is 50 mm unless otherwise noted.
- For skew angles shown in table, the length W and quantities for wingwalls are computed for a 1V:1.5H side slope. For 1V:2H or 1V:2.5H slopes compute length W with the following equation:
 $W = D/2 \times \text{slope} \times \text{secant (wingwall skew angle)}$
 Minimum W not less than 1.8 meters.
- Quantities shown in table are for one wingwall only. For lengths W not shown in table, approximate the quantities by multiplying the quantities for 0° skew and a given height H by the factor: $1 + [(W-1.8) \times 0.46]$.
- See Standards M601-1 and M601-2 for headwall and slope paving dimensions.
- Final quantities will be determined by using the tables on this standard.
- Do not order materials until the length, skew angle, and slope bevel in the field have been approved.
- Dimensions without units are millimeters.

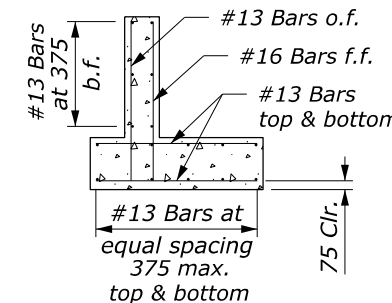

SECTION A-A

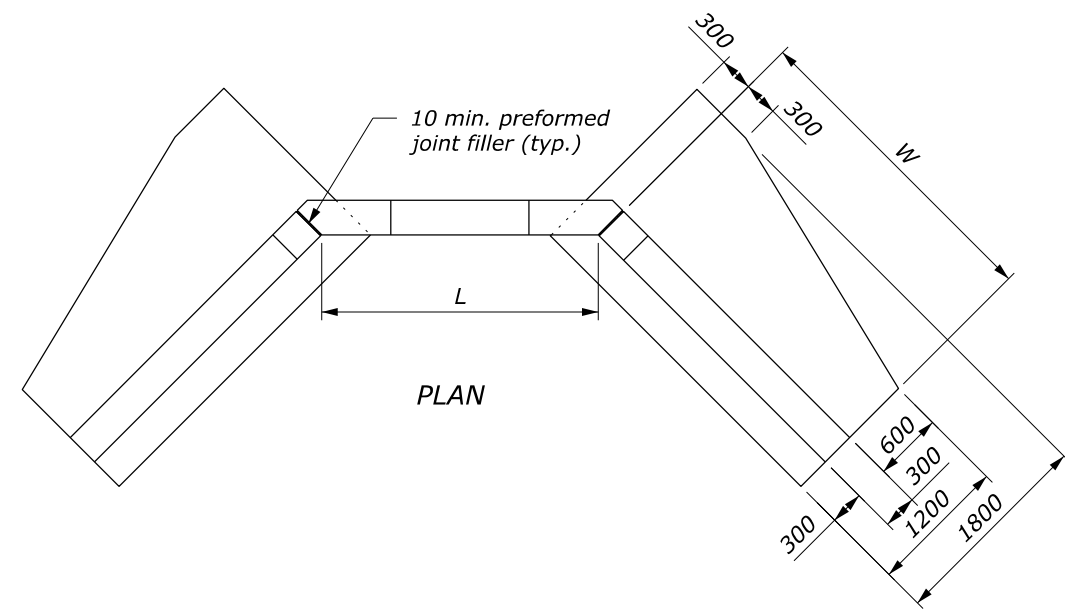

PLAN

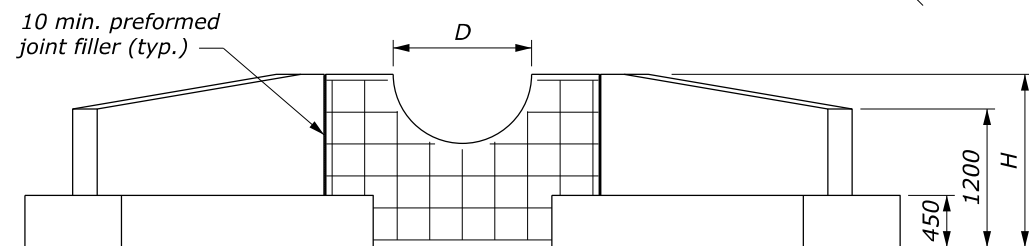

ELEVATION

HEADWALL AND WINGWALL

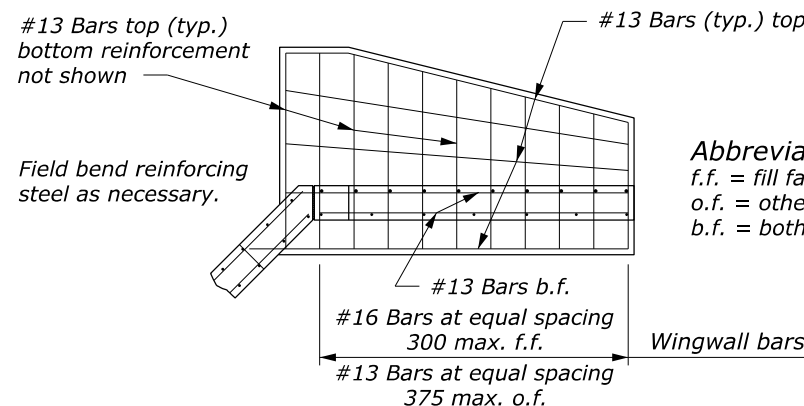

PLAN

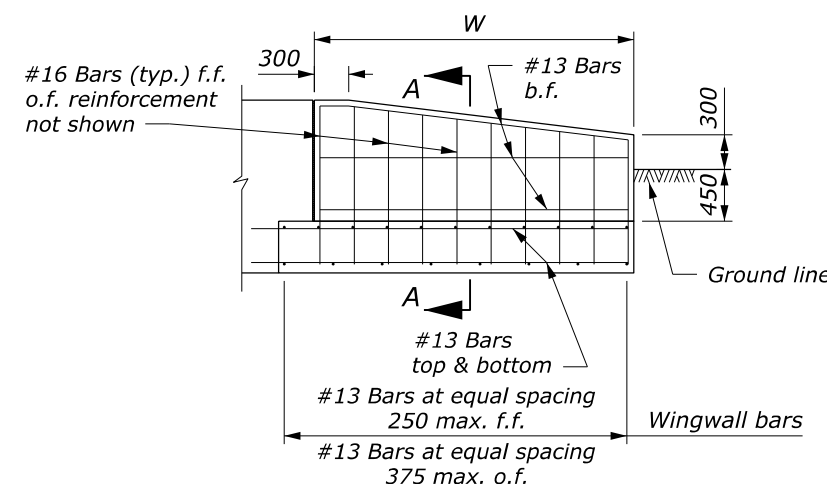

ELEVATION

TYPICAL WINGWALL

Abbreviations:
 f.f. = fill face
 o.f. = other face
 b.f. = both faces

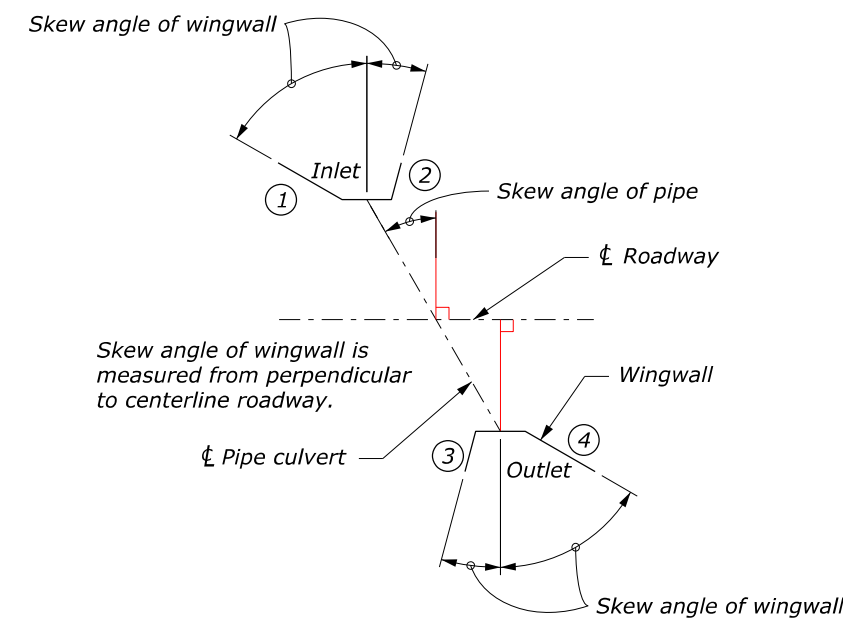

WINGWALL LAYOUT

U.S. DEPARTMENT OF TRANSPORTATION
 FEDERAL HIGHWAY ADMINISTRATION
 OFFICE OF FEDERAL LANDS HIGHWAY

METRIC FLH STANDARD

**WINGWALLS FOR
 CONCRETE HEADWALLS**

STANDARD APPROVED FOR USE 3/1996
 REVISED: 5/1997 6/2005 6/2007

STANDARD
 M601-3

NO SCALE