

PLAN

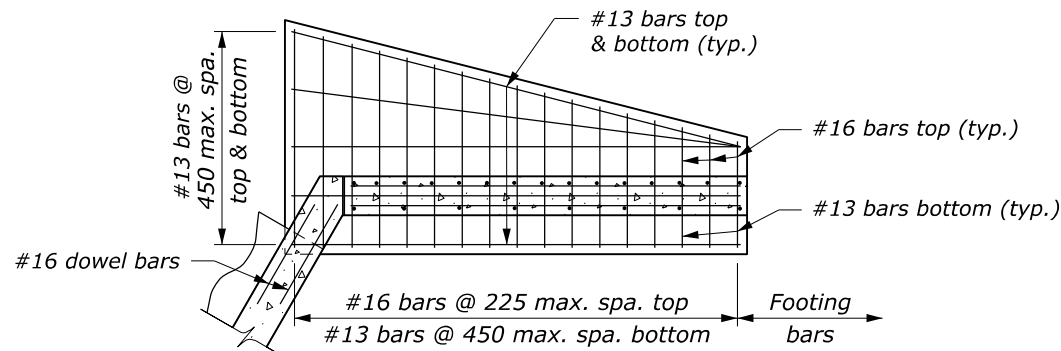

WINGWALL PLAN

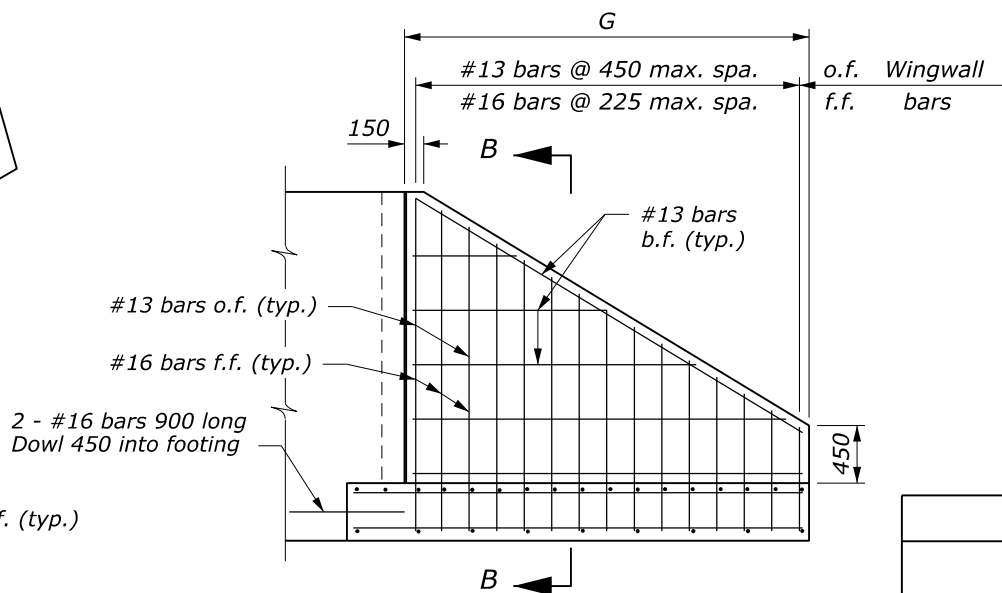

WINGWALL ELEVATION

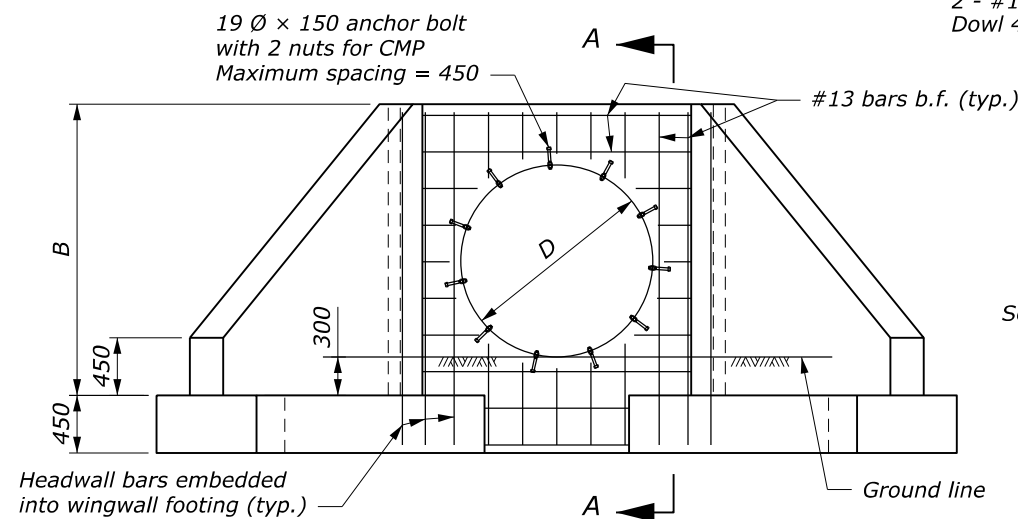

FRONT ELEVATION
(Showing headwall reinforcement)

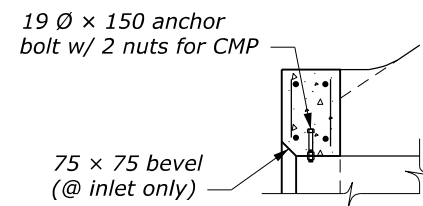

DETAIL C
(For Metal Pipes)

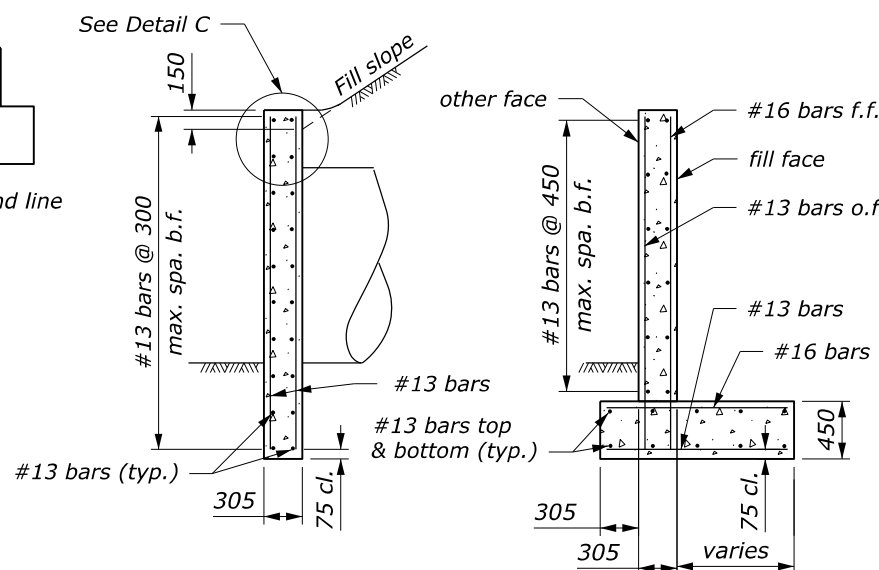

SECTION A-A

SECTION B-B

NOTE:

1. This detail applies for normal crossings and skews up to 15°.
2. On shallow fill where headwall is 600 mm or less below shoulder line, construct the headwall parallel to line and grade of the shoulder.
3. Do not allow top of wingwall to project above fill slope, ditch slope or shoulder.
4. Concrete shall conform to Section 601. Chamfer all exposed edges 20 mm and finish all exposed surfaces with a Class 1 ordinary surface finish. Joint filler shall conform to AASHTO M213 and shall be subsidiary to concrete quantity.
5. Bell end of concrete pipe may replace bevel at inlet headwall.
6. Quantities shown in table are for one headwall and two wingwalls and are based on CMP. Concrete and steel quantities shown will be used as basis for final payment for headwall/wingwalls constructed according to this standard.
7. Reinforcing steel clearance is 50 mm unless shown otherwise.
8. Anchor bolts shall conform to ASTM A307. Galvanize bolts and nuts to conform to ASTM A153. Anchor bolts shall be subsidiary to reinforcing steel quantity.
9. Dimensions without units are millimeters.

DIMENSIONS AND QUANTITIES

| | | D (Diameter of pipe culvert) | | | | | | | |
|--------------------|-------------------------|------------------------------|------|------|------|------|------|------|------|
| | | 1050 | 1200 | 1350 | 1500 | 1650 | 1800 | 1950 | 2100 |
| 1V:1.5H fill slope | A | 1675 | 1830 | 1980 | 2135 | 2285 | 2440 | 2590 | 2745 |
| | B | 1815 | 1970 | 2120 | 2275 | 2425 | 2580 | 2730 | 2885 |
| | C | 2025 | 2180 | 2330 | 2485 | 2635 | 2790 | 2940 | 3095 |
| | E | 1180 | 1315 | 1450 | 1580 | 1710 | 1845 | 1975 | 2110 |
| | F | 2050 | 2280 | 2505 | 2735 | 2960 | 3195 | 3420 | 3655 |
| | G | 2365 | 2630 | 2895 | 3160 | 3420 | 3690 | 3950 | 4220 |
| | Conc. (m ³) | 6.1 | 6.9 | 7.7 | 8.5 | 9.4 | 10.2 | 11.1 | 12.1 |
| Steel (kg) | 295 | 334 | 371 | 398 | 443 | 471 | 522 | 567 | |
| 1V:2H fill slope | A | 1675 | 1830 | 1980 | 2135 | 2285 | 2440 | 2590 | 2745 |
| | B | 1815 | 1970 | 2120 | 2275 | 2425 | 2580 | 2730 | 2885 |
| | C | 2025 | 2180 | 2330 | 2485 | 2635 | 2790 | 2940 | 3095 |
| | E | 1575 | 1755 | 1925 | 2110 | 2280 | 2460 | 2635 | 2815 |
| | F | 2730 | 3040 | 3340 | 3650 | 3950 | 4260 | 4560 | 4870 |
| | G | 3150 | 3510 | 3855 | 4215 | 4560 | 4920 | 5265 | 5625 |
| | Conc. (m ³) | 7.7 | 8.6 | 9.6 | 10.7 | 11.8 | 12.9 | 14.0 | 15.2 |
| Steel (kg) | 362 | 413 | 454 | 501 | 547 | 596 | 642 | 705 | |

Abbreviations:
 f.f. = Fill face
 o.f. = Other face
 b.f. = Both faces

U.S. DEPARTMENT OF TRANSPORTATION
 FEDERAL HIGHWAY ADMINISTRATION
 OFFICE OF FEDERAL LANDS HIGHWAY
 METRIC FLH STANDARD
**CONCRETE HEADWALL/WINGWALL
 FOR SINGLE NORMAL
 1050 TO 2100 PIPE CULVERT**

STANDARD APPROVED FOR USE 3/1996
 REVISED: 5/1997 6/2005
 STANDARD M601-5

NO SCALE