

ABOVE NATURAL GROUND

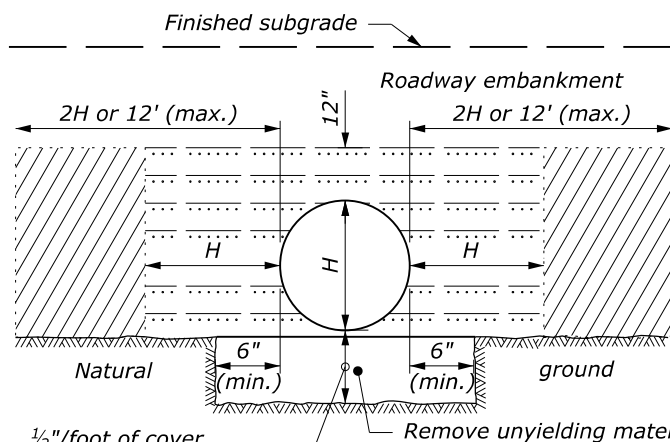

ON UNYIELDING MATERIAL

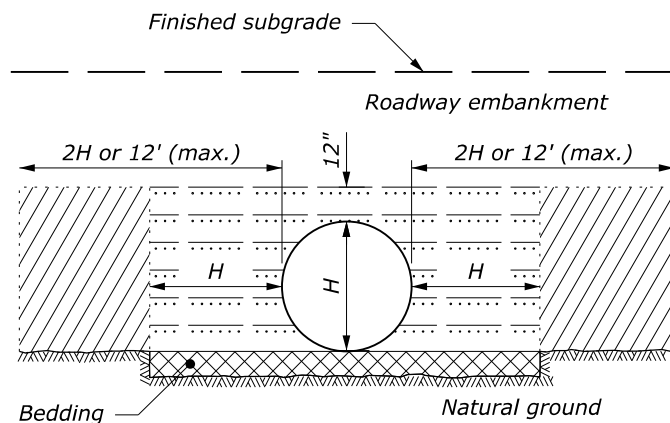

ON NATURAL GROUND

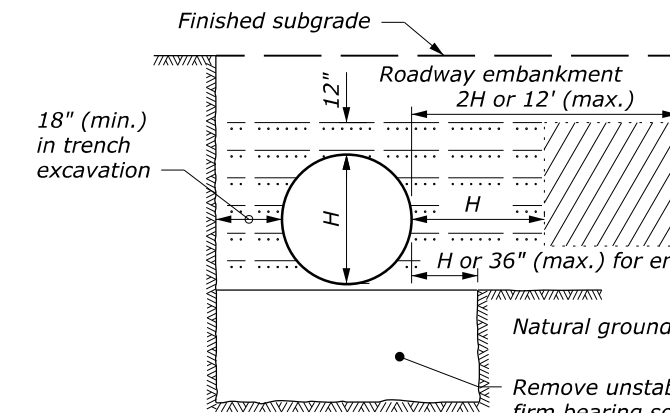

ON UNSTABLE MATERIAL

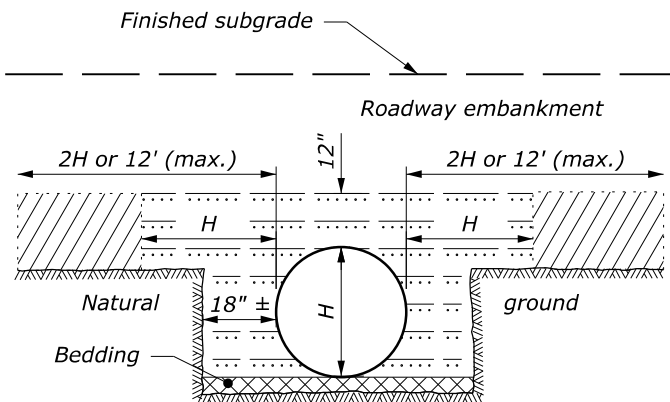

ABOVE AND BELOW NATURAL GROUND

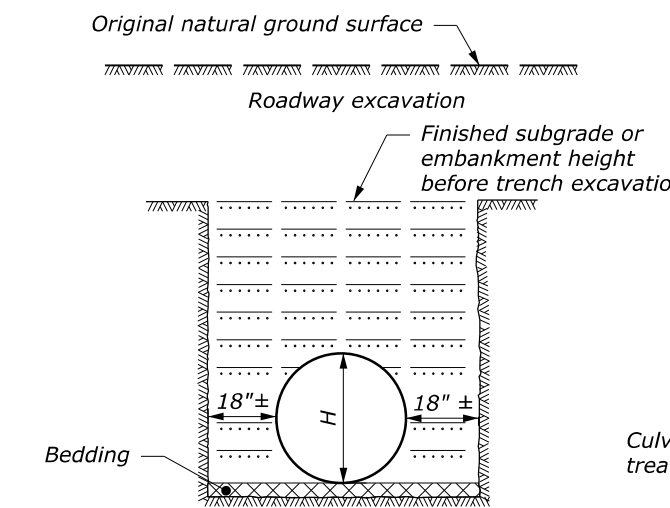

BELOW NATURAL GROUND OR TRENCH EXCAVATION IN EMBANKMENT

BEDDING DEPTH	
PIPE SIZE (H)	DEPTH
12" to 54"	4"
> 54"	6"

NOTE:

1. When directed, camber pipe culverts upward from a chord through the inlet and outlet inverts an ordinate amount equal to 1% of the pipe length. Develop camber on a parabolic curve. If the midpoint elevation on the parabolic curve as designed exceeds the elevation of the inlet invert, reduce the amount of camber or increase the pipe culvert gradient.
2. H equals the diameter of all round pipe culverts or the rise dimension of all pipe arch culverts.
3. See Section 704 for bedding and backfill requirements.

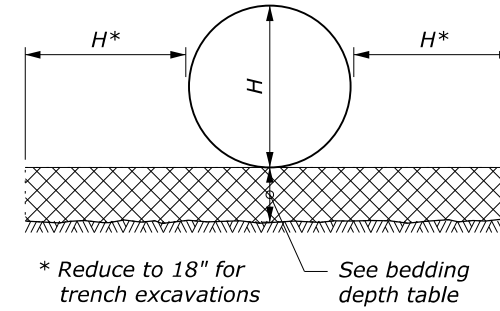

PIPE BEDDING

MINIMUM SPACING	
DIAMETER or SPAN	SPACING
UP to 48"	24"
48" and UP	Half diameter or span or 36", whichever is less

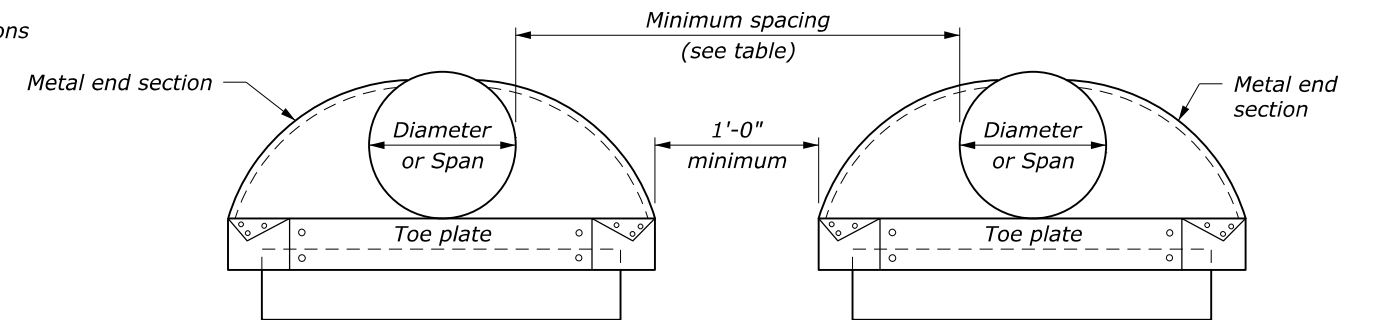

ELEVATION

MULTIPLE PIPE INSTALLATION

LEGEND:

- Bedding material (uncompacted)
- Embankment material placed in layers not exceeding 6" compacted depth.
- Compacted backfill material placed in layers not exceeding 6" compacted depth; or lean concrete backfill in accordance with Section 614.
- Impermeable backfill material.

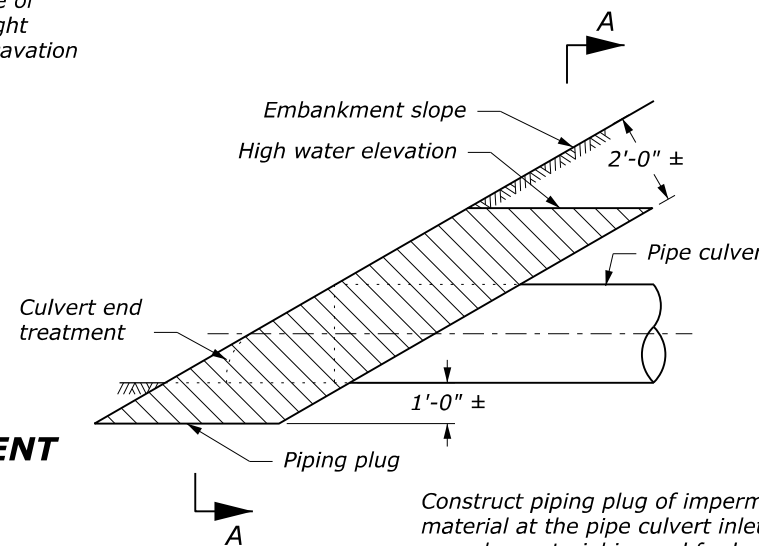

PIPING PLUG

NO SCALE

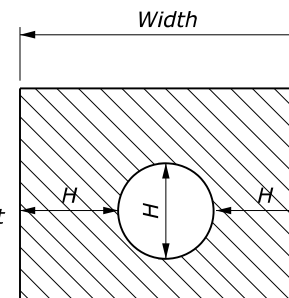

SECTION A-A

U.S. DEPARTMENT OF TRANSPORTATION
FEDERAL HIGHWAY ADMINISTRATION
OFFICE OF FEDERAL LANDS HIGHWAY

FLH STANDARD

METAL AND PLASTIC PIPE CULVERT BEDDING

STANDARD APPROVED FOR USE 12/1993
REVISED: 4/1994 6/2005
DRAFT: 10/2017

STANDARD
602-3