

END SECTIONS FOR ROUND PIPE CULVERT

PIPE SIZE DIAMETER INCHES	METAL THICKNESS				DIMENSIONS INCHES					SLOPE Approx.
	STEEL		ALUMINUM		A (min)	B (max)	H (min)	L (±2")	W (max)	
	INCHES	GAGE	INCHES	GAGE						
12	0.064	16	0.060	16	5	7	6	21	44	2 1/4
15	0.064	16	0.060	16	6	8	6	26	52	2 1/4
18	0.064	16	0.060	16	7	10	6	31	58	2 1/8
21	0.064	16	0.060	16	8	12	6	36	66	2 1/8
24	0.064	16	0.060	16	9	13	6	41	72	2 1/8
30	0.079	14	0.075	14	11	16	8	51	88	2 1/8
36	0.079	14	0.075	14	13	19	9	60	105	2
42	0.109	12	0.105	12	15	25	10	69	122	2 1/8
48	0.109	12	0.105	12	17	29	12	78	131	2
54	0.109	12	0.105	12	17	33	12	84	143	2
60	0.109	12	0.105	12	17	36	12	87	157	1 7/8
66	0.109	12	0.105	12	17	39	12	87	162	1 5/8
72	0.109	12	0.105	12	17	44	12	87	169	1 1/2
78	0.109	12	0.105	12	17	48	12	87	178	1 3/8
84	0.109	12	0.105	12	17	52	12	87	184	1 1/3
90	0.109	12	0.105	12	17	58	12	87	188	1 1/4
96	0.109	12	0.105	12	17	58	12	87	197	1 1/8

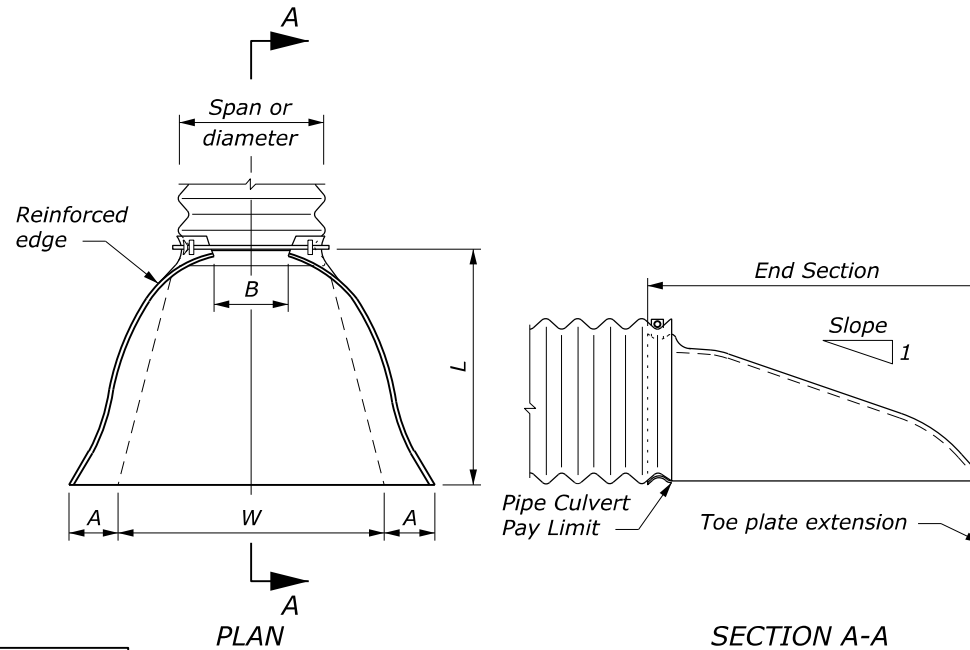

ROUND OR PIPE ARCH CULVERT

PIPE SIZE SPAN x RISE INCHES	EQUI-VALENT DIAM. (INCHES)	METAL THICKNESS				DIMENSIONS INCHES					SLOPE Approx.
		STEEL		ALUMINUM		A (min)	B (max)	H (min)	L (±2")	W (max)	
		INCHES	GAGE	INCHES	GAGE						
17 x 13	15	0.064	16	0.060	16	7	9	6	19	30	2 1/2
21 x 15	18	0.064	16	0.060	16	7	10	6	23	36	2 1/2
24 x 18	21	0.064	16	0.060	16	8	12	6	28	42	2 1/2
28 x 20	24	0.064	16	0.060	16	9	14	6	32	48	2 1/2
35 x 24	30	0.079	14	0.075	14	10	16	8	39	60	2 1/2
42 x 29	36	0.079	14	0.075	14	12	18	9	46	75	2 1/2
49 x 33	42	0.109	12	0.105	12	13	21	12	53	85	2 1/2
57 x 38	48	0.109	12	0.105	12	18	26	12	63	90	2 1/2
60 x 46	54	0.109	12	0.105	12	18	34	12	70	102	2
64 x 43	54	0.109	12	0.105	12	18	30	12	70	102	2
66 x 51	60	0.109	12	0.105	12	18	33	12	77	116	1 1/2
71 x 47	60	0.109	12	0.105	12	18	33	12	77	114	1 1/2
73 x 55	66	0.109	12	0.105	12	18	36	12	77	126	1 1/2
77 x 52	66	0.109	12	0.105	12	18	36	12	77	126	1 1/2
81 x 59	72	0.109	12	0.105	12	18	39	12	77	138	1 1/2
83 x 57	72	0.109	12	0.105	12	18	39	12	77	138	1 1/2
87 x 63	78	0.109	12	0.105	12	20	38	12	77	148	1 1/2
95 x 67	84	0.109	12	0.105	12	20	34	12	87	162	1 1/2
103 x 71	90	0.109	12	0.105	12	20	38	12	87	174	1 1/2
112 x 75	96	0.109	12	0.105	12	20	40	12	87	174	1 1/2

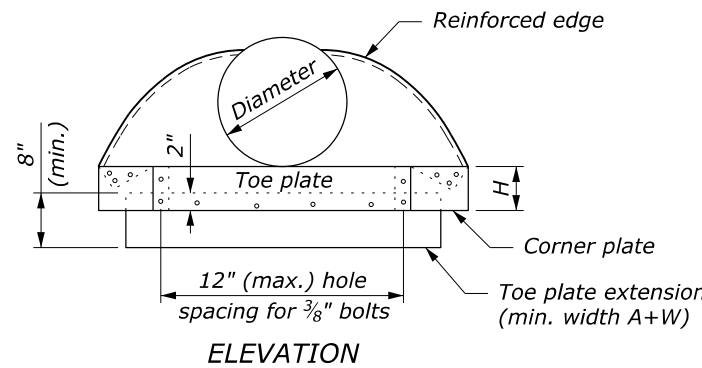

ROUND PIPE CULVERT

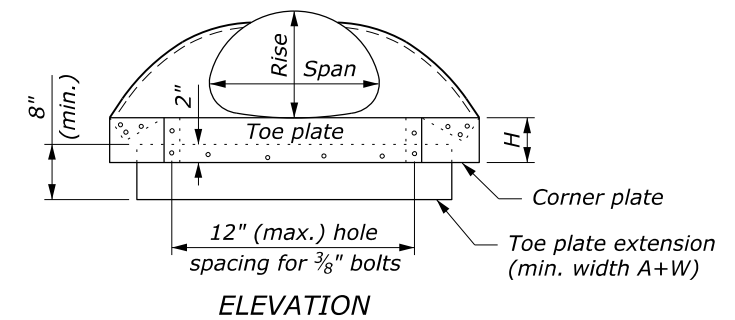

PIPE ARCH CULVERT

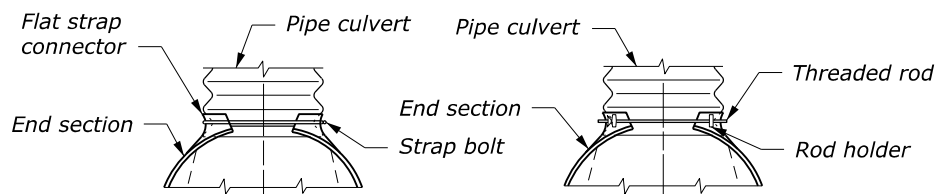

For 12" thru 24" round pipe and 17" x 13" thru 28" x 20" pipe arch
 For 30" thru 60" round pipe and 35" x 24" thru 66" x 51" pipe arch

DESIGN A CONNECTION TO ANNULAR CORRUGATED METAL PIPE

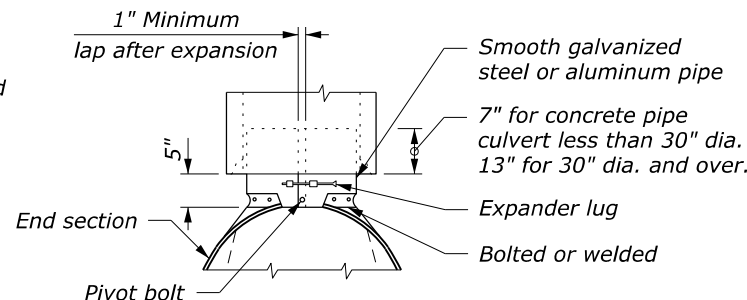

DESIGN B CONNECTION TO CONCRETE PIPE INLET END

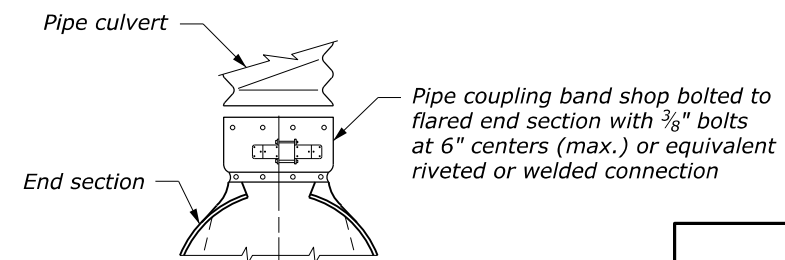

DESIGN C CONNECTION TO METAL PIPE OR OUTLET END OF CONCRETE PIPE

NO SCALE

NOTE:

- Variations in design and dimensions are permitted to allow for manufacturer's standards.
- Fabricate the diameter of the end section of Design B to match the inside diameter of the concrete pipe culvert.
- Design C may be used in lieu of design A for all metal pipe culvert sizes. Coupling bands may be any acceptable type for the pipe culvert specified.
- Fabricate multiple piece bodies with lap seams tightly joined by 3/8" rivets or bolts. Fabricate end section center panels for 60" and larger diameter pipe and equivalent pipe arch from 0.138 inch steel or 0.135 inch aluminum.
- On end section center panels for 66" and larger equivalent pipe arch provide 2 1/2" x 2 1/2" x 1/4" angle reinforcement bolted or riveted under the center panel seam.
- Supplement the reinforced edges of end sections for 60" and larger diameter pipe and 66" and larger equivalent pipe arch with 2 1/2" x 2 1/2" x 1/4" stiffener angles attached with bolts or rivets.
- Fabricate connector section, corner plate and toe plate extensions from the same metal thickness as the panel body. Use toe plate extension where shown on the plans.
- Warp embankment slopes to match the slope of the flared end sections.

U.S. DEPARTMENT OF TRANSPORTATION
 FEDERAL HIGHWAY ADMINISTRATION
 OFFICE OF FEDERAL LANDS HIGHWAY

FLH STANDARD

METAL END SECTIONS

STANDARD APPROVED FOR USE 12/1993
 REVISED: 4/1994 6/2005
 DRAFT: 10/2007

STANDARD
 602-4