

**ALTERNATE 1**

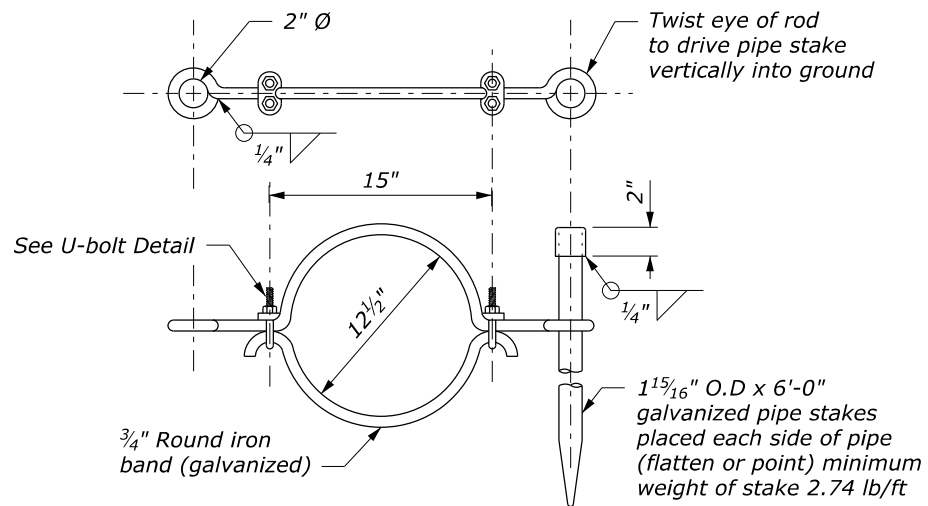

**ALTERNATE 2**

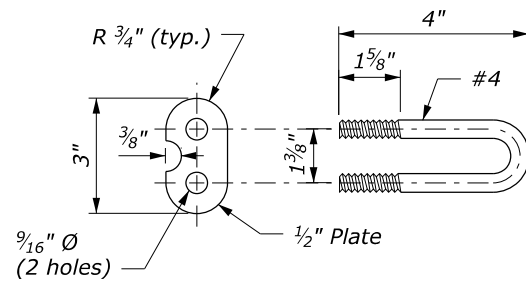

**U-BOLT DETAIL**

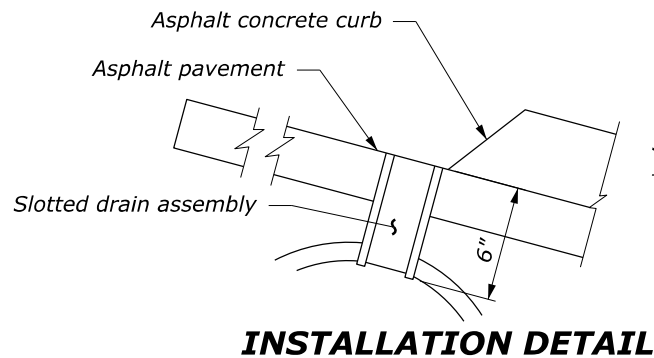

**INSTALLATION DETAIL**

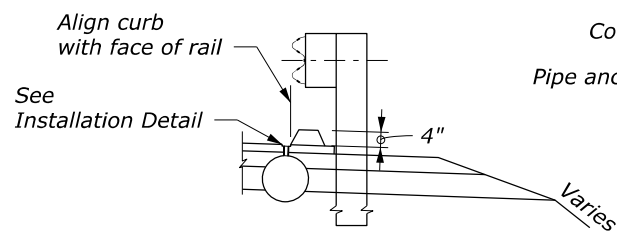

**TYPICAL PLACEMENT AT GUARDRAIL**

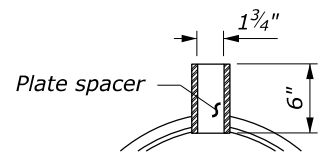

**SECTION B-B**

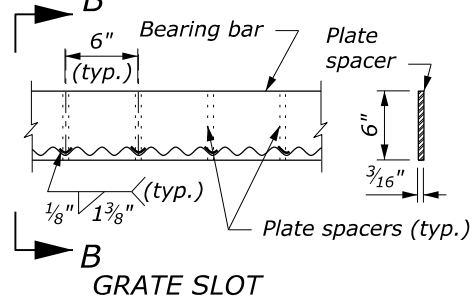

**GRATE SLOT**

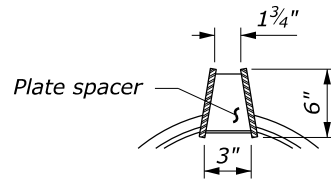

**SECTION C-C**

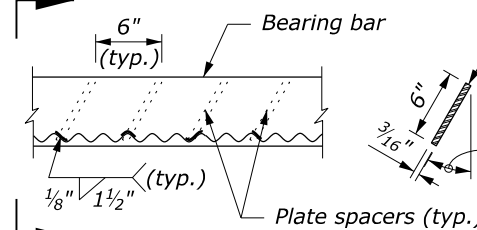

**ANGLE SLOT**

**SLOTTED DRAIN ASSEMBLY**

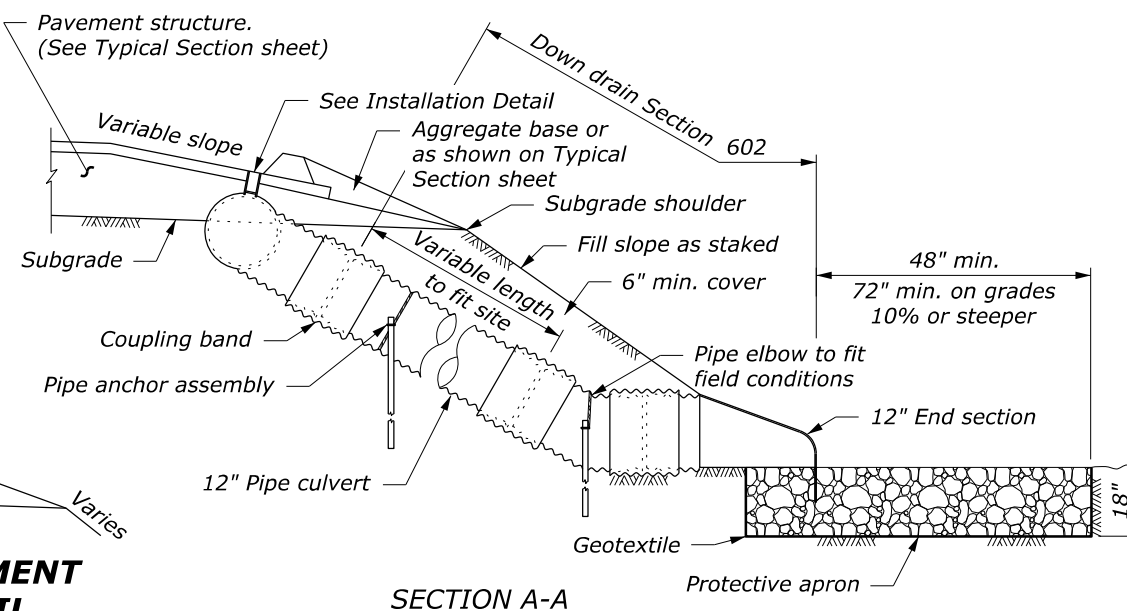

**SECTION A-A**

**NOTE:**

1. Fabricate slotted drain pipe, down drain pipe culvert, elbows, end section, and coupling bands from sheets 1/16" thickness.
2. Grate slot assembly and plate end plug conform to AASHTO M 183.
3. Galvanize grate slot assembly, plate end plug, and all hardware according to AASHTO M 111.
4. Approved alternate pipe anchor assemblies may be used.
5. Place Class 2 riprap conforming to Section 251 for protective apron.
6. Place pipe anchor assemblies approximately 20-foot intervals along down drain pipe culvert. Place a minimum of 2 anchors per down drain.
7. For installations at sag vertical curves, use a tee connection instead of an elbow and a minimum of two 20-foot slotted drain pipe sections.
8. Place gaskets under all band connections in accordance with Section 602. Refer to Standard 602-2 for coupling band details.
9. Use either the grate slot or the angle slot slotted drain assembly.

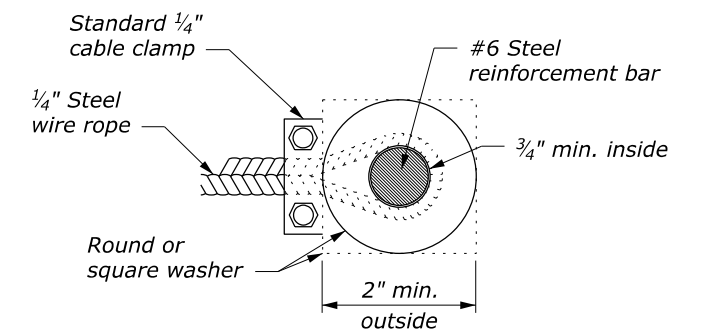

**DETAIL A**

NO SCALE

U.S. DEPARTMENT OF TRANSPORTATION FEDERAL HIGHWAY ADMINISTRATION OFFICE OF FEDERAL LANDS HIGHWAY	
FLH STANDARD	
<b>SLOTTED DRAIN SPILLWAY ASSEMBLY</b>	
STANDARD APPROVED FOR USE 6/2005	STANDARD
REVISED: DRAFT: 3/2014	606-1