

SECTION TRUNCATED DOME

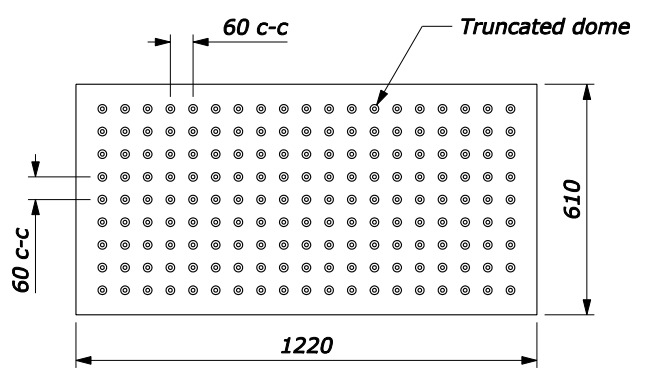

PLAN

DETECTABLE WARNING FIELD WITH TRUNCATED DOMES

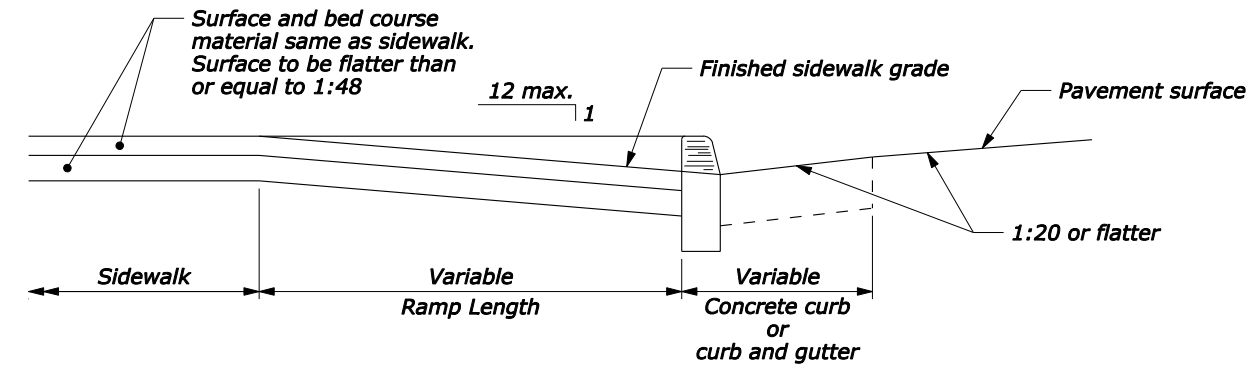

RAMP - TYPICAL SECTION

NOTE:

1. The maximum cross slopes of ramps must not exceed 2% in any direction.
2. Use a coarse broom finish running perpendicular to the slope to create a slip resistant surface on concrete ramp surfaces, exclusive of the detectable warning fields.
3. Construct curb ramp perpendicular to the curb. Avoid skewing the ramp face.
4. Construct ramp transitions between walks, gutters, or streets that are flush and free of abrupt vertical changes not to exceed 63 mm.
5. Locate drainage inlets and manholes outside of ramp walking surfaces or landings.
6. Dimensions without units are millimeters.

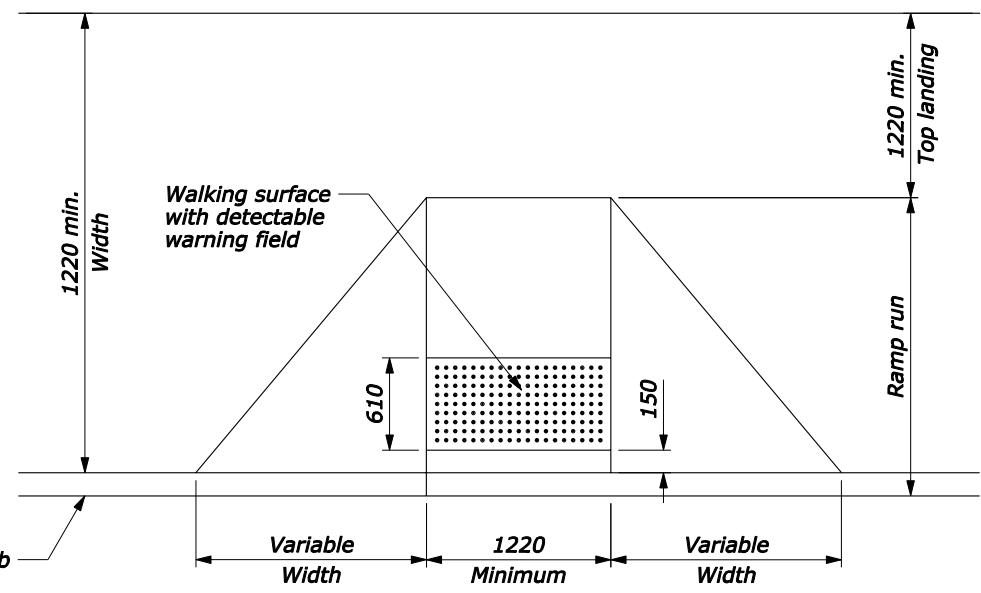

PERPENDICULAR CURB RAMP

FOR COMMENT

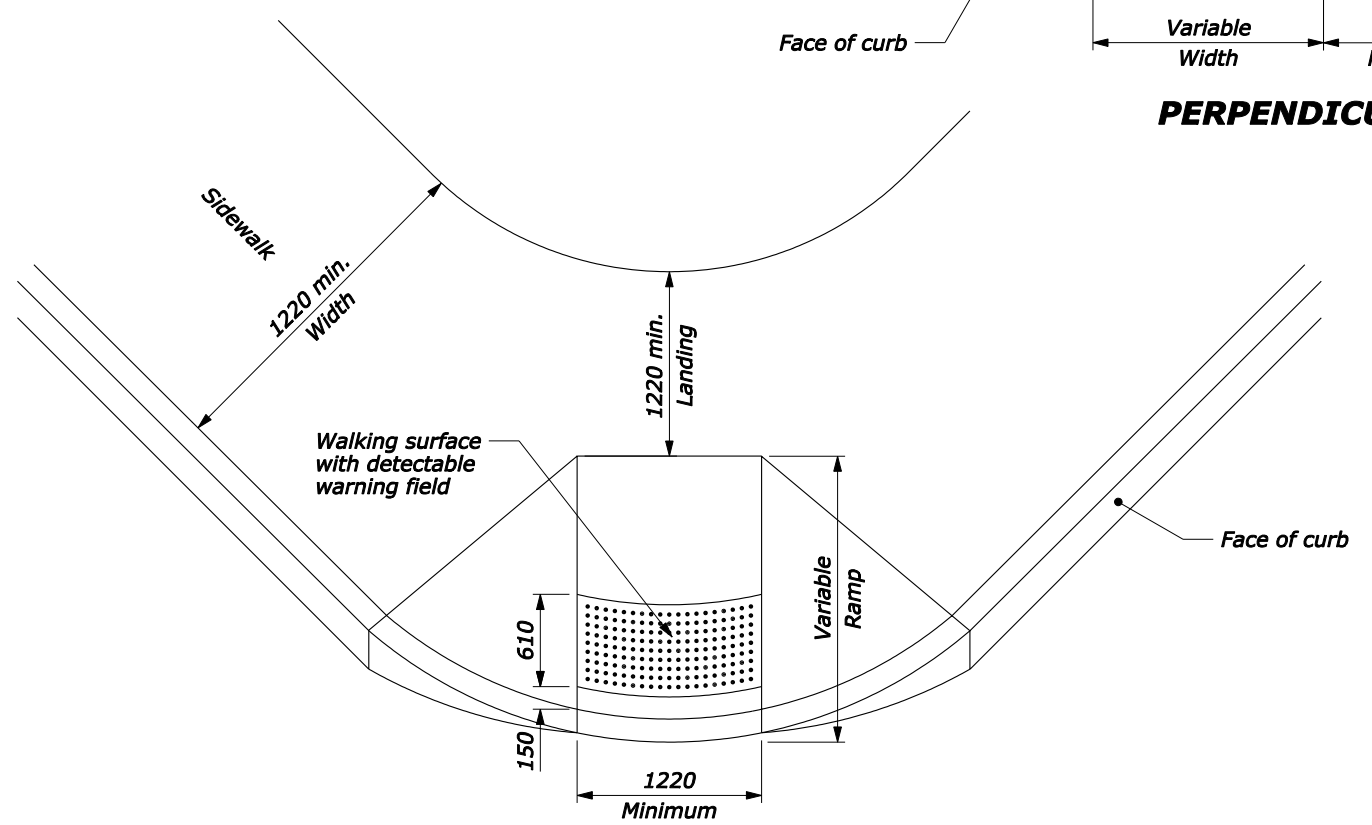

DIAGONAL CURB RAMP

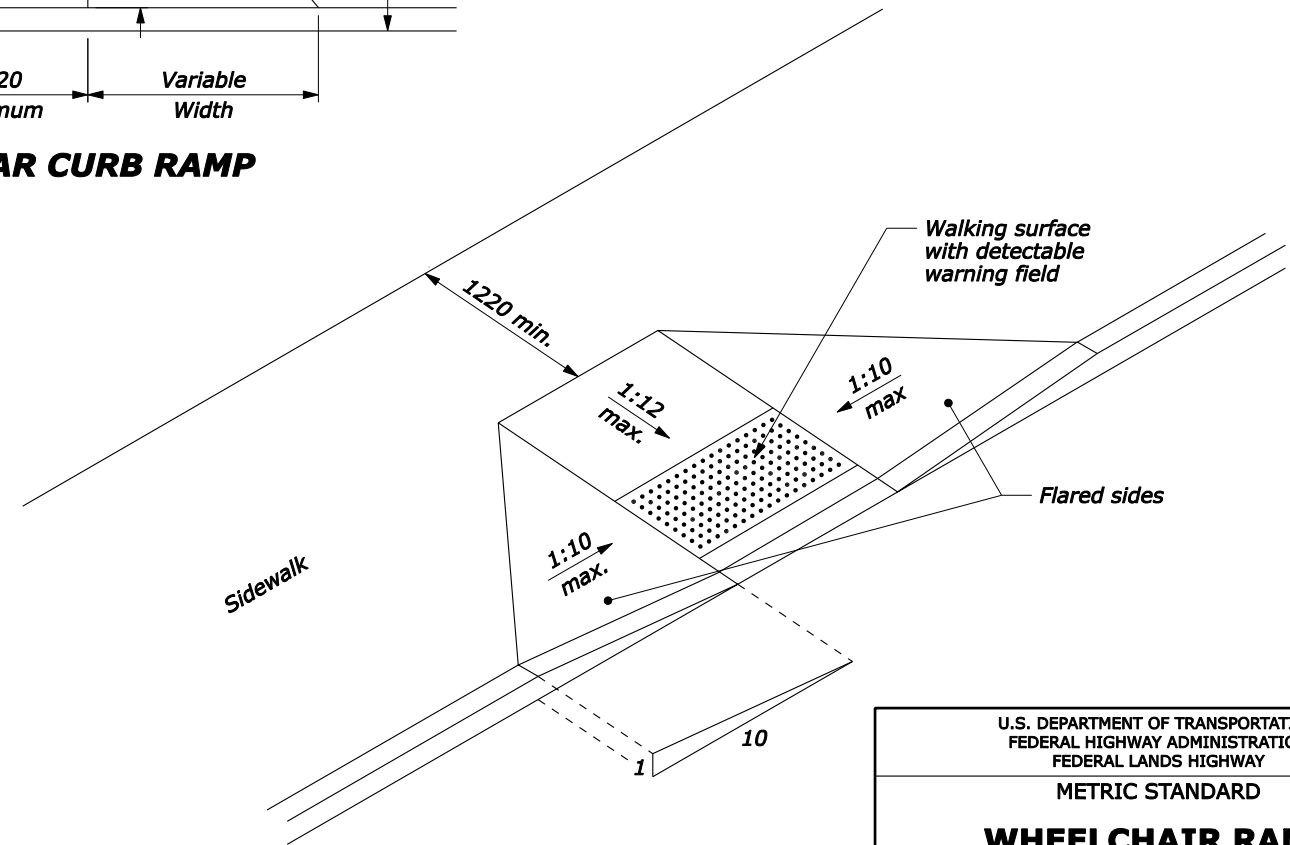

RAMP - ISOMETRIC

NO SCALE

U.S. DEPARTMENT OF TRANSPORTATION FEDERAL HIGHWAY ADMINISTRATION FEDERAL LANDS HIGHWAY	
METRIC STANDARD	
WHEELCHAIR RAMP CURB CUT	
STANDARD APPROVED FOR USE --/----	STANDARD M615-1
REVISED: DRAFT: 1/2004	