

POST AND BLOCK

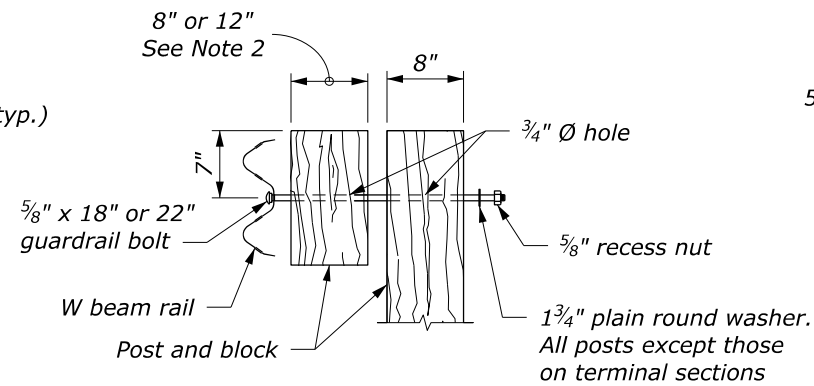

POST BOLT ASSEMBLY

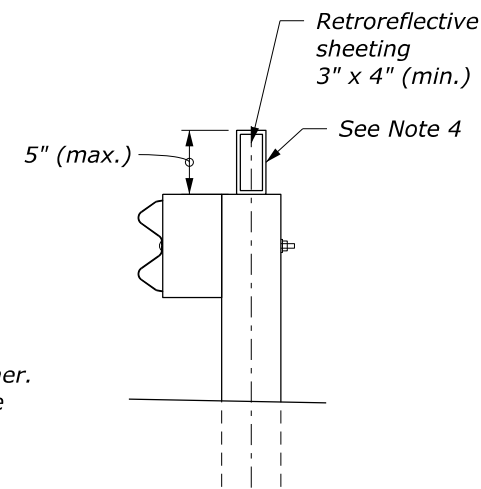

FLEXIBLE DELINEATOR GUARDRAIL MOUNT

NOTE:

1. When encountering impenetrable material, one post may be omitted in locations where the typical guardrail cross section includes 2-feet (min.) between the back of the guardrail post and the hinge point. For all other locations, see Section 617 and Standard 617-13 or 617-37.
2. Size of block shown elsewhere on the plans. Use a single block or combination of blocks (no more than two) to achieve the actual 8-inch or 12-inch offset. Secure wood blocks to the posts with anti-rotation nails. If combination blocks are used, toenail the adjacent blocks with two 16d galvanized nails to prevent block rotation.
3. Dimensional tolerances not shown or implied are intended to be those consistent with the proper functioning of the part, including its appearance, and accepted manufacturing practices.
4. Install a flexible hinged delineator every fourth post. Fasten delineator to the top of the wood post using either an adhesive or mechanical means according to the manufacturer's recommendations.

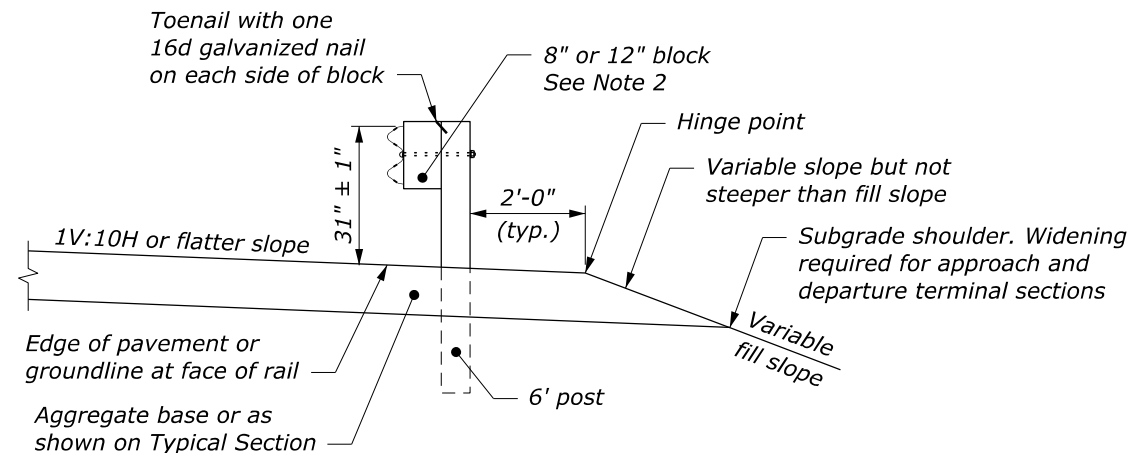

TYPICAL GUARDRAIL CROSS SECTION 6' POST, 8" OR 12" BLOCK

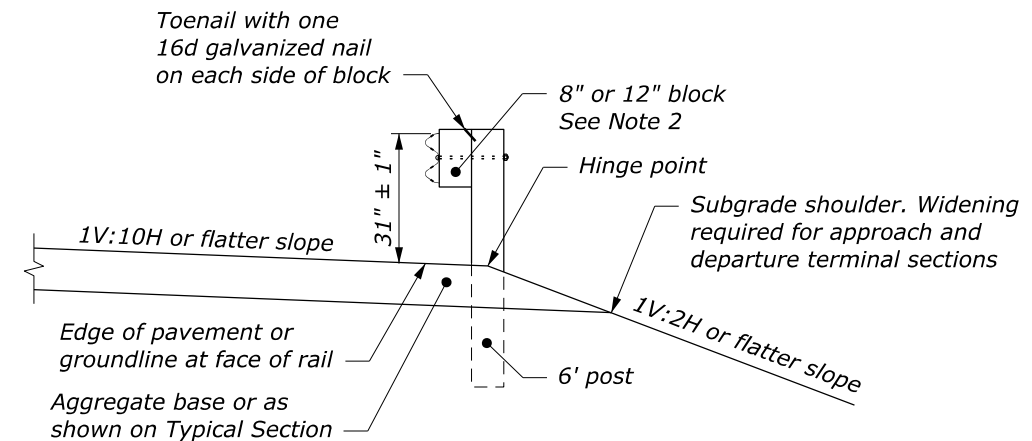

TYPICAL GUARDRAIL CROSS SECTION 6' POST CENTERED ON HINGE, 8" OR 12" BLOCK

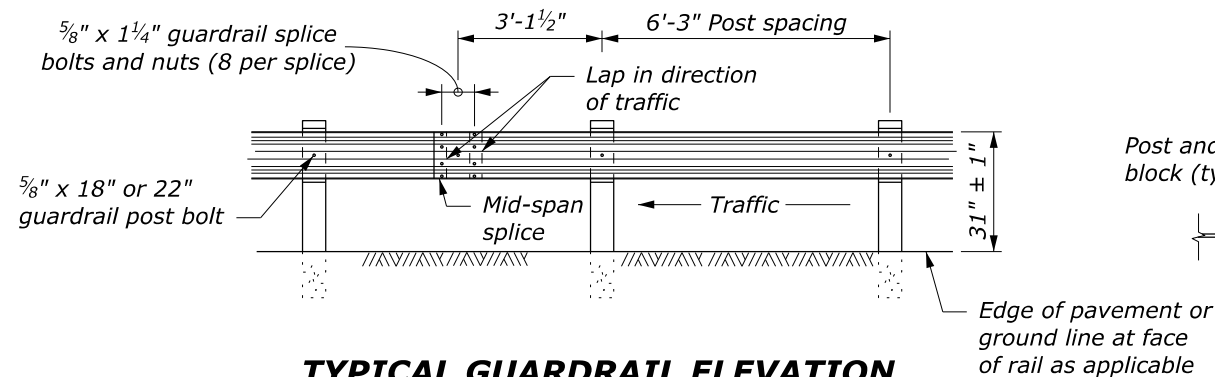

TYPICAL GUARDRAIL ELEVATION

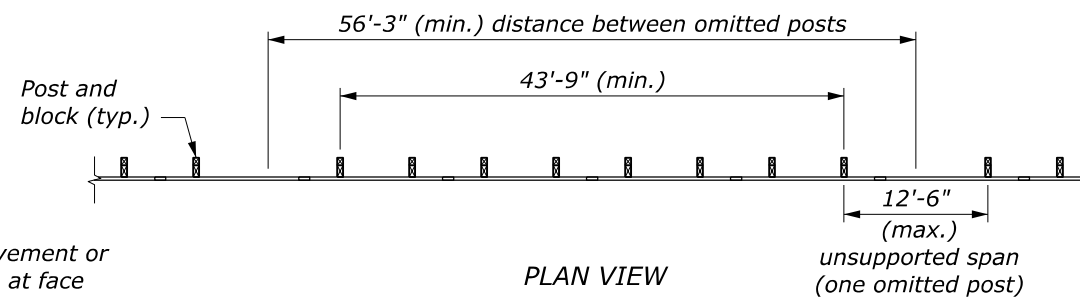

PLAN VIEW OMITTED POST DETAIL
See Note 1

NO SCALE

U.S. DEPARTMENT OF TRANSPORTATION
FEDERAL HIGHWAY ADMINISTRATION
OFFICE OF FEDERAL LANDS HIGHWAY

FLH STANDARD

MGS W-BEAM GUARDRAIL WOOD POSTS

STANDARD APPROVED FOR USE 7/2022
REVISED:

STANDARD
617-31

Designer Notes: FLH Standard Drawing 617-31
Last Updated: June 2022

MGS W-Beam Guardrail, Wood Posts

General Information

Appropriate Applications.

- The Midwest Guardrail System (MGS) is a non-proprietary w-beam guardrail system that meets the current crash testing requirements. MGS is used when w-beam guardrail is selected for barrier installation.

Crash Test Criteria	MASH
Test Level	TL-3
FHWA Eligibility Letter	B-133, B-211A
TF 13 Designator	SGR20a-b, SGR38a-e
Crash Test Report	Multiple MwRSF reports available at https://mwrsf.unl.edu/mgs.php

Limitations. The drawing shows the various options for guardrail near slopes. The preferred option is to use 6' post with 2' between the back of post and the slope hinge point.

Layout Guidance.

- See AASHTO *Roadside Design Guide*
- Use the FLH Barrier Length of Need Calculator available at <https://highways.dot.gov/federal-lands/safety/barrier-length-need>
- See the FLH *Midwest Guardrail System FAQ* document for more information.

Typical Pay Item Used

- 61701-4550 Guardrail system MGS, type 2, class A wood posts [LNFT] for galvanized steel
- 61701-5150 Guardrail system MGS, type 4, class B wood posts [LNFT] for weathering steel

Updates

February 2019

- New Detail drawing

June 2022

- Converted from CFL Detail to FLH Standard