

APPROACH & DEPARTURE FLARE WITH FLARED ANCHOR TERMINAL (FAT)

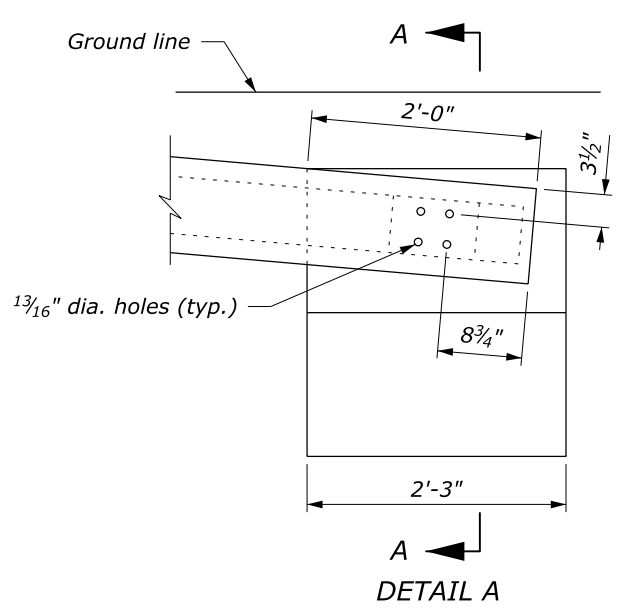

CONCRETE ANCHOR

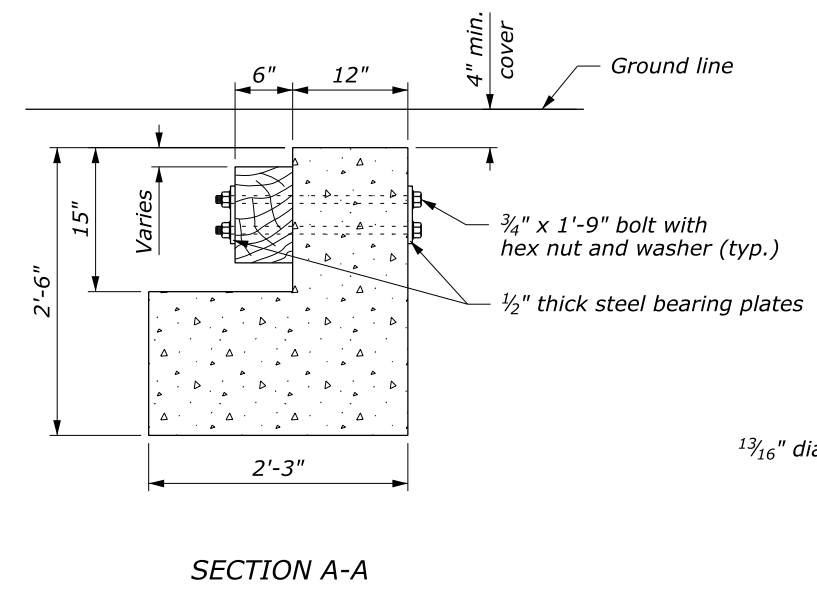

SECTION A-A

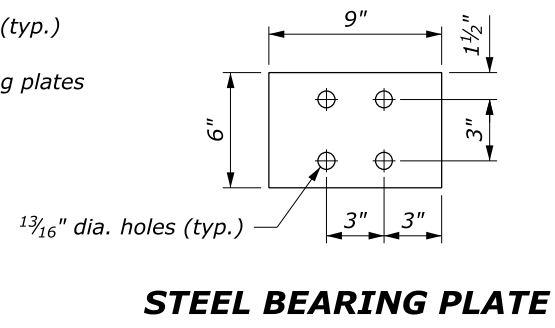

STEEL BEARING PLATE

Design Speed (mph)	Shy line offset (ft)	Flare rate inside shy line (a:b)	Flare rate outside shy line (a:b)
60	8.0	26:1	14:1
50	6.5	21:1	11:1
40	5.0	16:1	8:1
30 and less	3.5	13:1	7:1

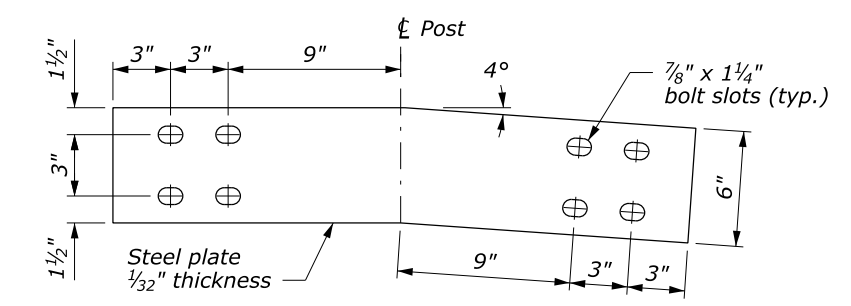

ANGLED STEEL SPLICE PLATE

NOTE:

1. Extend the fill widening a minimum of 5 feet behind the guardrail, unless otherwise directed by the CO.
2. The guardrail flare shown in the plan view is the minimum length and rate required. As directed by the CO, flare the guardrail so that the terminal section is outside the clear zone. If the terminal section cannot be located outside the clear zone, it should be flared as far as practical from the road at the maximum rate indicated on the Guardrail Flare Rates table.
3. See Standard 617-60, Steel-Backed Timber Guardrail, Type SBT-A and SBT-B, for timber, structural steel, and hardware details.
4. On the Type A, blocked-out guardrail, include the blocks in terminal section, except on the concrete anchor. For the Type B, non-blocked-out guardrail, no blocks are included.

U.S. DEPARTMENT OF TRANSPORTATION
 FEDERAL HIGHWAY ADMINISTRATION
 FEDERAL LANDS HIGHWAY

U.S. CUSTOMARY STANDARD

**STEEL-BACKED TIMBER GUARDRAIL
 TERMINAL SECTION
 TYPE SBT-FAT**

STANDARD APPROVED FOR USE 1/1990

REVISSED: 4/1994 6/2005
 DRAFT: 12/2013

STANDARD
 617-61

NO SCALE