

SECTION VIEW

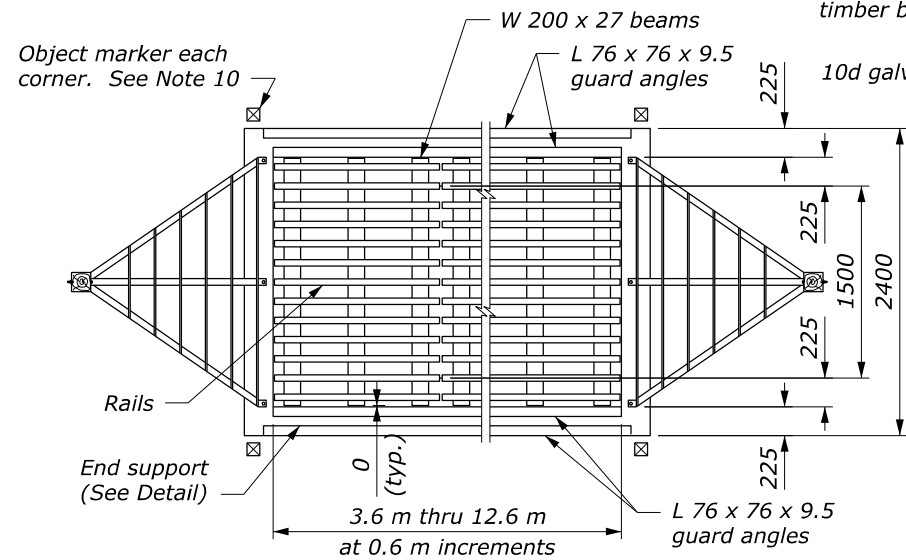

PLAN

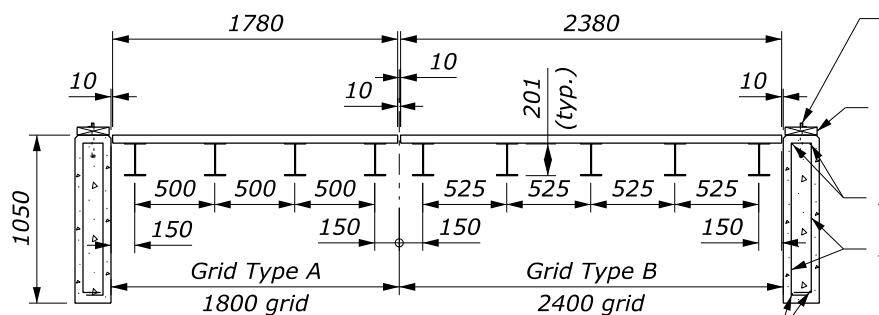

STANDARD GRID UNIT TYPES

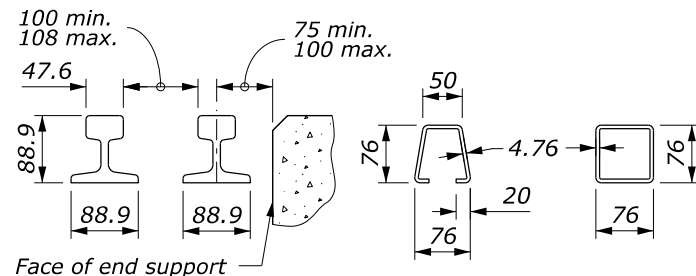

ACCEPTABLE ALTERNATE RAIL

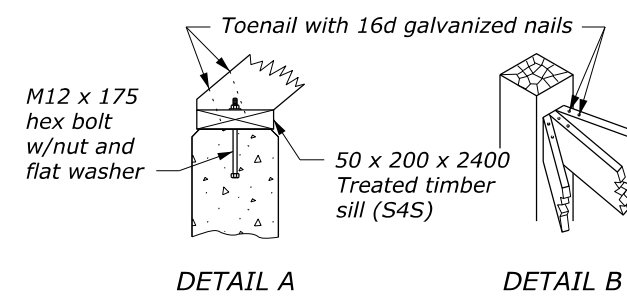

DETAIL A

DETAIL B

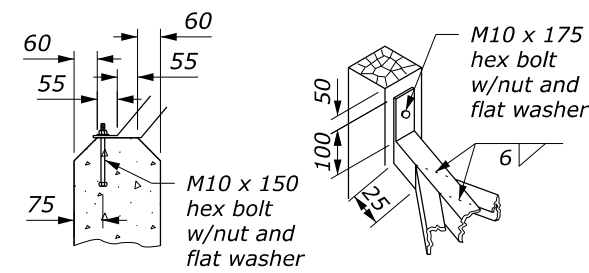

DETAIL C

DETAIL D

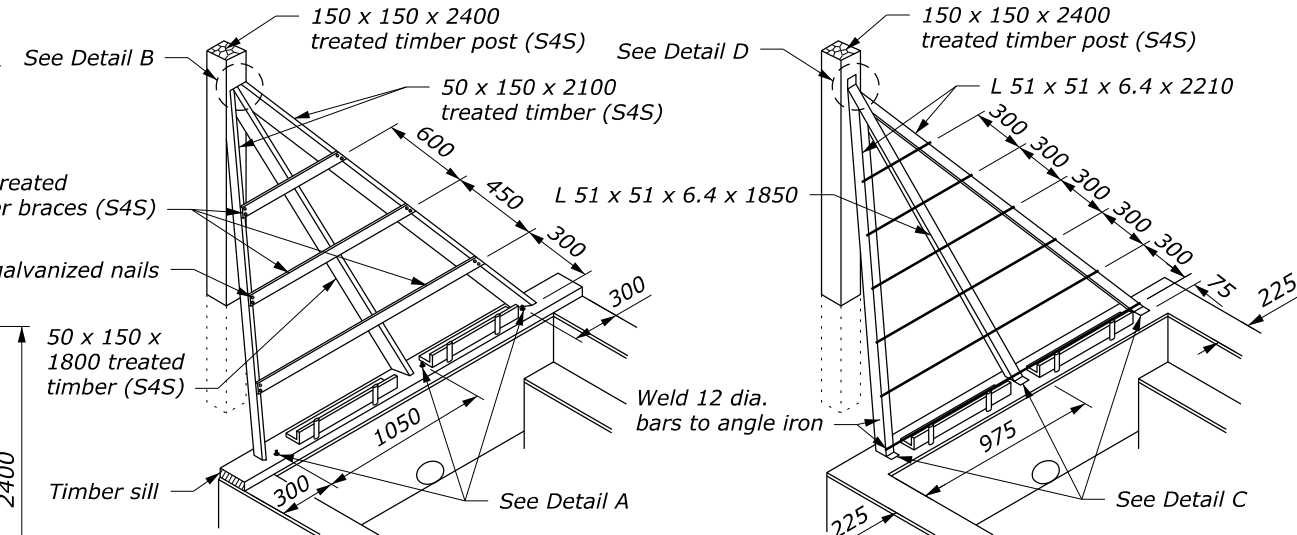

WOOD WING GUARD

ANGLE IRON WING GUARD

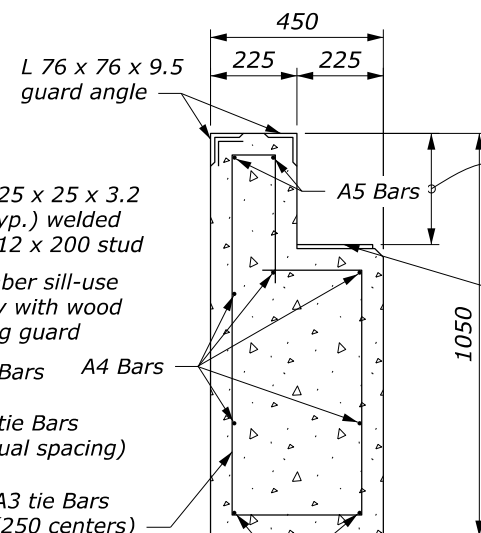

END SUPPORT DETAIL
(#13 Reinforcing Bars)

GUARD ANGLE DETAIL
(4 required per cattle guard)

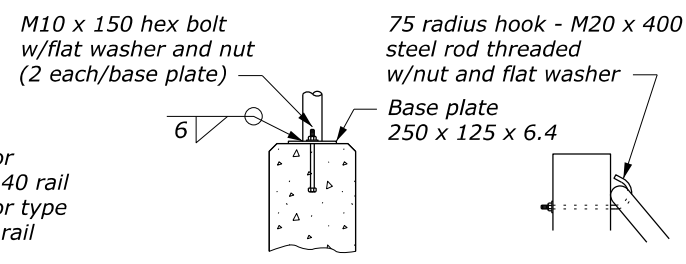
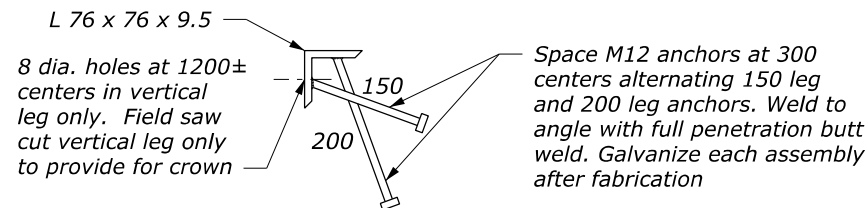

DETAIL E

DETAIL F

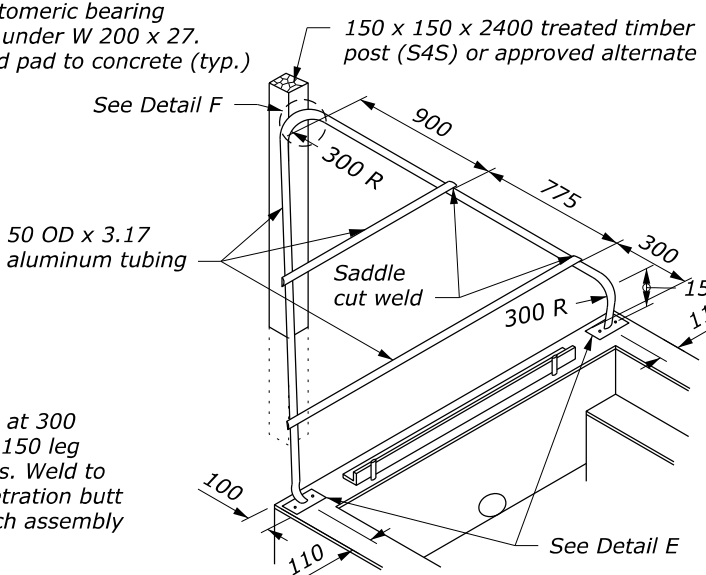

ALUMINUM TUBING WING GUARD

NOTE:

- LOADING: AASHTO MS18.
- CONCRETE: Chamfer exposed edges 20 mm unless otherwise shown. Give all concrete surfaces a Class 1 finish.
- STRUCTURAL STEEL: Provide rails conforming to the requirements for ASCE 40 crane rail. Provide structural steel for alternate sections conforming to ASTM A 500, Grade B, Copper Steel or ASTM A 618, Grade 2. If the steel does not contain a minimum of 0.2 percent copper, galvanize the alternate sections. All other structural steel conforms to AASHTO ASTM A36 and is painted.
- Provide 50 mm minimum concrete cover to the face of any bar unless otherwise shown. All bars are #13.
- All welds are continuous 6 mm fillet shop welds. Weld rail or alternate sections on both sides to the W 200 x 27 beams at each intersection. Weld according to Section 555.
- Use aluminum alloy 6061-T6 or 6063-T6 for aluminum tubing.
- Provide timber conforming to AASHTO M 168. Treat timber with chromated copper arsenate according to AASHTO M 133.
- Galvanize all hardware according to AASHTO M 111.
- Construct the cattle guard to conform with the finished roadway grade and template.
- Place one object marker at each corner of the cattle guard as shown. Mount object markers on 100 x 100 x 1950 posts with the reflector located 1050 mm above the elevation of the lateral support concrete.
- Install drain pipe as shown where required. Include drain pipe with cattle guard unless otherwise shown.
- Unless otherwise shown in the Special Contract Requirements, shop apply paint system 2 according to Section 555 and color the top coat according to Federal Standard 595B, Gray, 36231. Repair any damage to the paint system during installation.
- Install channels and wood blocking on cattle guards wider than 4.8 m to maintain grate spacing as shown on Standard M619-2.
- See Standard M619-3 for optional precast foundation details.
- Dimensions without units are millimeters.

NO SCALE