

**CONTRACTION JOINT**  
UNDOWELED - TRANSVERSE and  
UNTIED - LONGITUDINAL

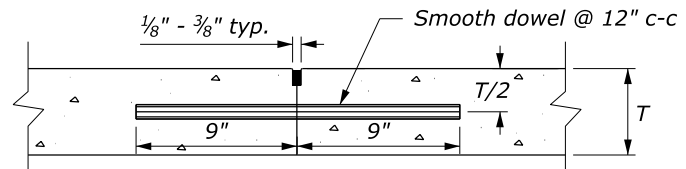

**CONSTRUCTION JOINT**  
DOWEL BUTT - TRANSVERSE

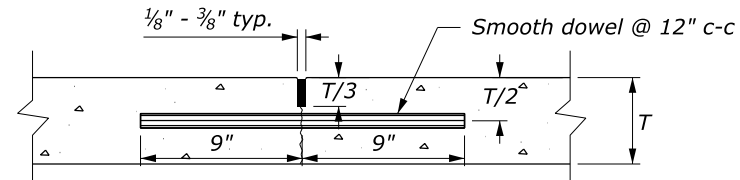

**CONTRACTION JOINT**  
DOWELED - TRANSVERSE

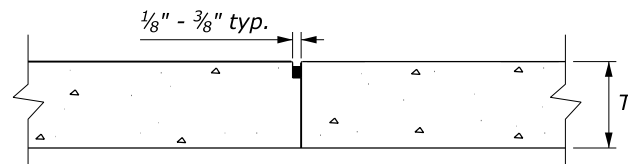

**CONSTRUCTION JOINT**  
PLAIN - TRANSVERSE or LONGITUDINAL

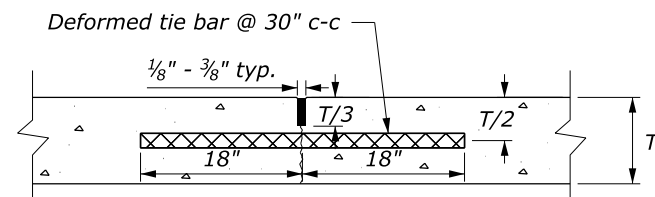

**CONTRACTION JOINT**  
TIED - LONGITUDINAL

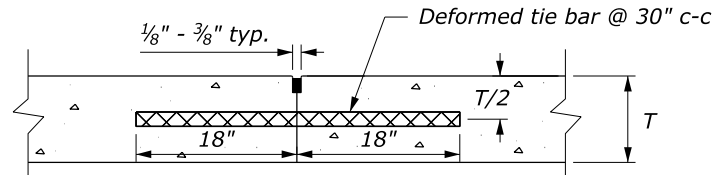

**CONSTRUCTION JOINT**  
TIED BUTT - LONGITUDINAL

**NOTE:**

1. Use epoxy-coated material for all tie bars, dowels, and other steel used in the construction of concrete pavement.
2. Use deformed reinforcing bars for tie bars.
3. Install isolation joints when abutting a fixed structure. Use expansion joint material extending the full depth and length of the concrete surface.
4. Transverse and longitudinal construction joints are not included in the joint layout plan. Use transverse and longitudinal construction joints sparingly. Submit planned construction joint locations to the CO for approval.
5. Do not place tie bars within 15" of transverse joints.
6. For construction joints, if tie bars and dowels are not set into concrete during placement, drill and anchor the tie bars and dowels into the existing concrete construction with epoxy resin.
7. Maintain joint sealant shape factor of 1:1 except when silicone sealant is used, the width to depth shape factor is 2:1 or as recommended by sealant manufacturer.

Pavement Thickness (T) (inches)	Tie Bar	Dowel Bar Diameter (inches)
$T \leq 8$	#5	1
$8 < T \leq 10$	#5	1 1/4
$10 < T \leq 12$	#6	1 1/2

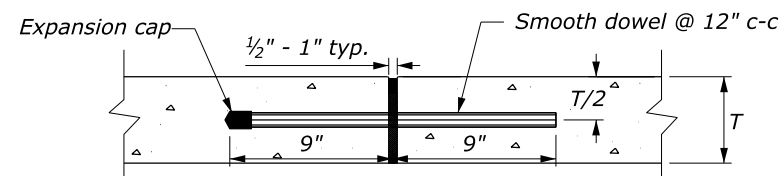

**ISOLATION JOINT**  
DOWELED - TRANSVERSE

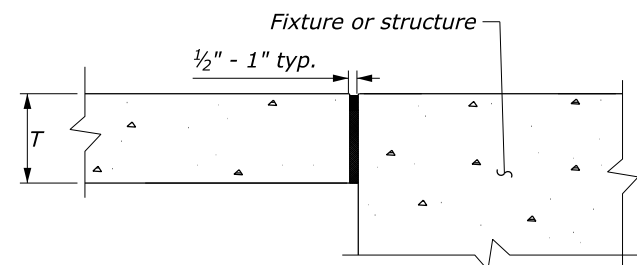

**ISOLATION JOINT**  
UNDOWELED - LONGITUDINAL

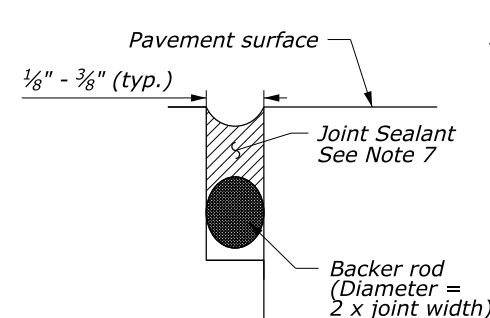

CONSTRUCTION JOINT

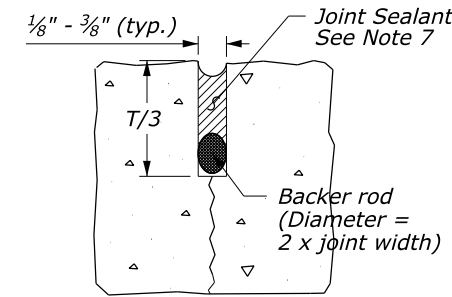

SAWED OR FORMED JOINT

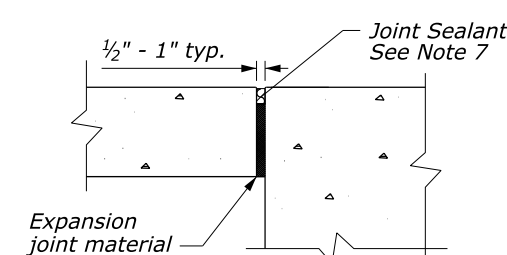

ISOLATION JOINT

**JOINT SEALING DETAILS**

U.S. DEPARTMENT OF TRANSPORTATION  
FEDERAL HIGHWAY ADMINISTRATION  
CENTRAL FEDERAL LANDS HIGHWAY DIVISION

U.S. CUSTOMARY DETAIL

**MINOR CONCRETE  
PAVEMENT JOINTS**

DETAIL APPROVED FOR USE 07/2013

REVISED: 08/2014

DETAIL

C501-50

NO SCALE

## NOTES TO THE DESIGNER

Last Updated: August 2014

---

### General Information

1. **Joint types.** Joints should be placed in all rigid pavements. Most jointed concrete pavement failures can be attributed to failures at the joint, as opposed to inadequate structural capacity.
    - The most common types of pavement joints, which are defined by their function, are as follows:
      - *Transverse Contraction Joint* - a sawed, formed, or tooled groove in a concrete slab that creates a weakened vertical plane. It regulates the location of the cracking caused by dimensional changes in the slab, and is by far the most common type of joint in concrete pavements.
      - *Longitudinal Joint* - a joint between two slabs which allows slab warping without appreciable separation or cracking of the slabs.
      - *Construction Joint* - a joint between slabs that results when concrete is placed at different times. This type of joint can be further broken down into transverse and longitudinal joints.
  2. **Layout Guidance.**
    - Provide a joint layout plan and this detail for all rigid pavements. Coordinate joint layout with pavements and materials engineer.
- 

### Applicable SCRs

1. Section 703:  
<http://www.cflhd.gov/resources/design/constructspecs/scr/fp14/documents/S703-14.docx>
- 

### Typical Pay Item Used

- 50101-??00 Minor Concrete Pavement, reinforced, [6-inch to 12-inch] depth SQYD
  - 50102-??00 Minor Concrete Pavement, plain, [6-inch to 12-inch] depth SQYD
- 

### Updates

July 2013

- New CFL detail drawing

August 2014

- Updated for FP-14
- Updated border