

**CABLE ANCHOR PLATE DETAILS**

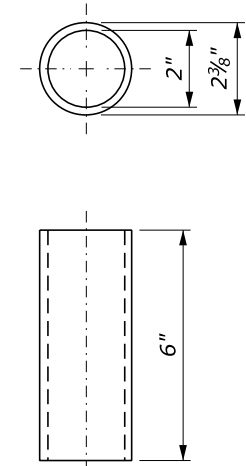
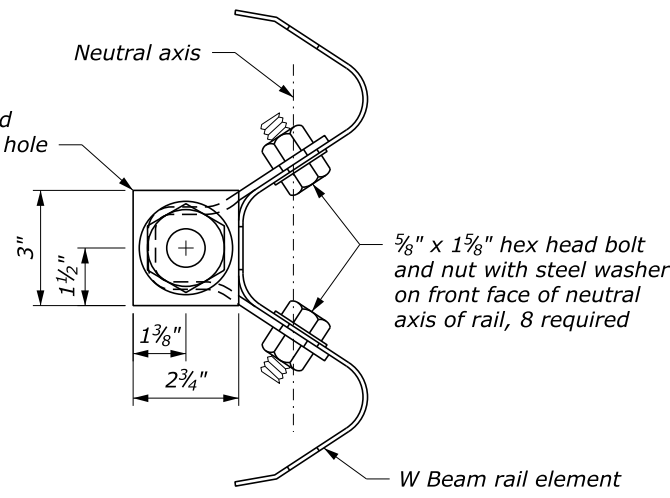

**POST SLEEVE**

**NOTE:**

1. Dimensional tolerances not shown or implied are intended to be those consistent with the proper functioning of the part, including its appearance, and accepted manufacturing practices.

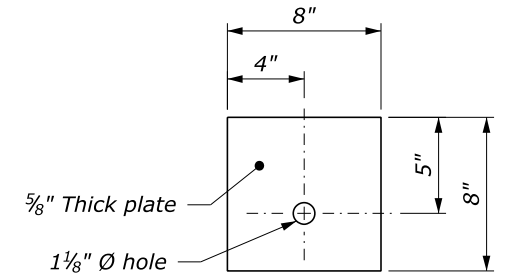

**BEARING PLATE**

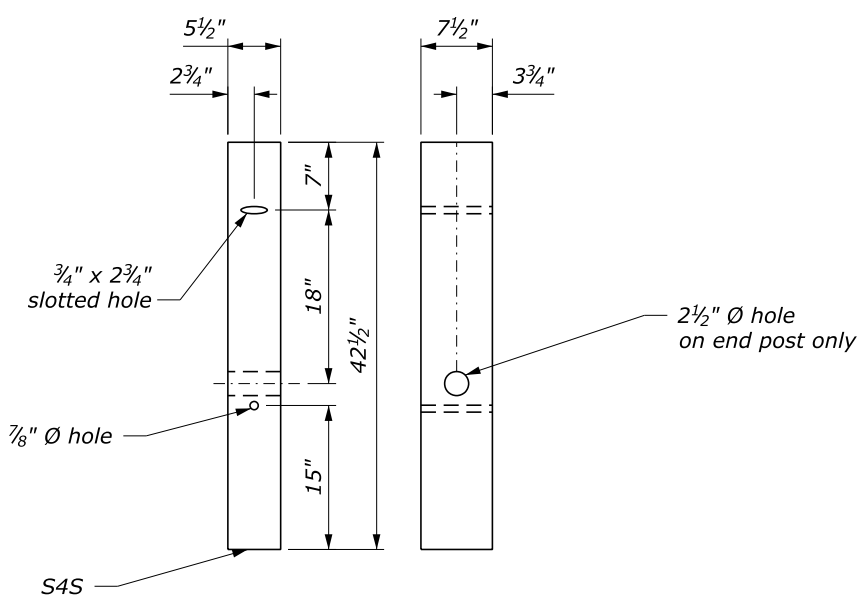

**TERMINAL POST**

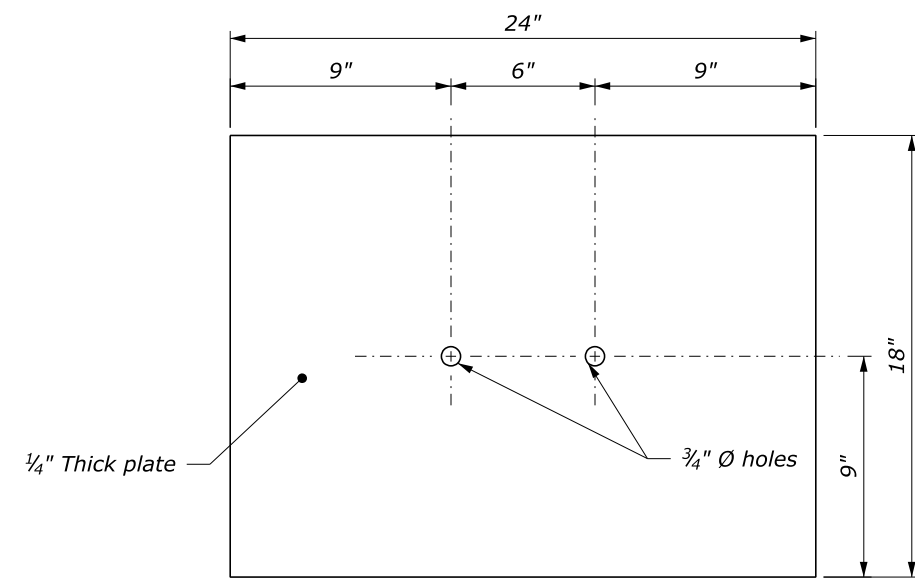

**SOIL PLATE  
(2 REQUIRED)**

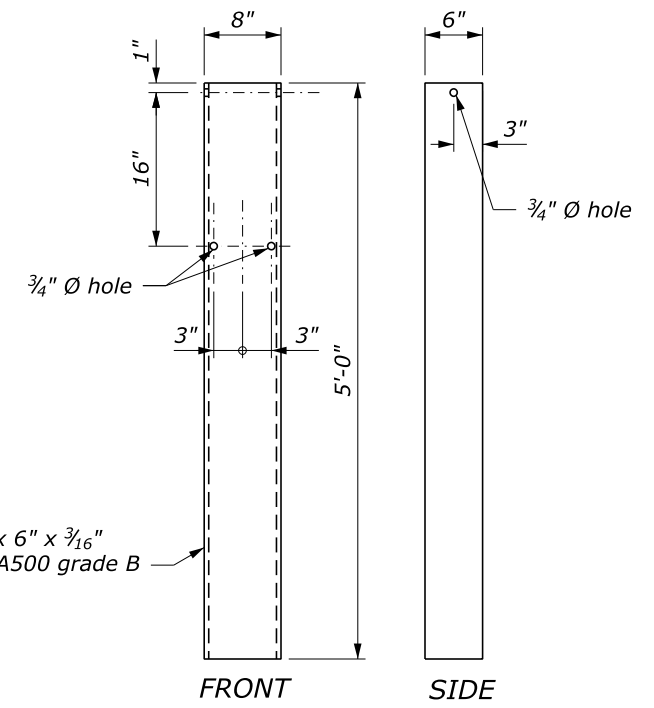

**STEEL TUBE ANCHOR**

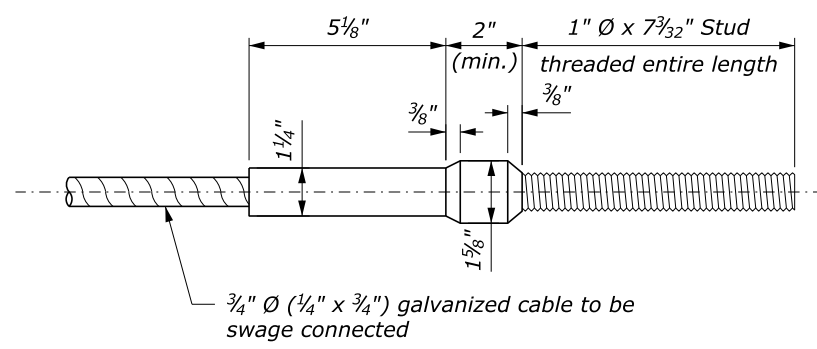

**CABLE ANCHOR ASSEMBLY  
(Standard swaged fitting and stud)**

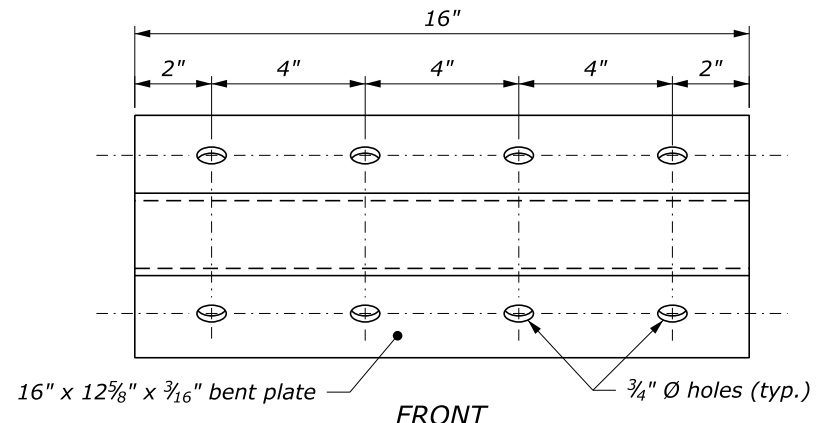

**GUARDRAIL ANCHOR BRACKET**

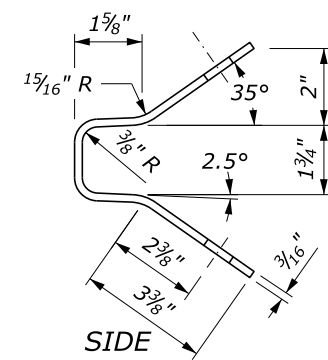

NO SCALE

U.S. DEPARTMENT OF TRANSPORTATION  
FEDERAL HIGHWAY ADMINISTRATION  
CENTRAL FEDERAL LANDS HIGHWAY DIVISION

U.S. CUSTOMARY DETAIL  
**G4 W-BEAM GUARDRAIL  
CRT ANCHORAGE ASSEMBLY  
DETAILS**

DETAIL APPROVED FOR USE 04/2020	DETAIL
REVISED:	C617-23

\$\$\$DATE\$\$\$  
 \$\$\$TIME\$\$\$  
 \$\$\$DGN\$\$\$  
 \$\$\$USER\$\$\$