

END SECTIONS FOR ROUND PIPE CULVERT

PIPE SIZE DIAMETER INCHES	METAL THICKNESS				DIMENSIONS INCHES					SLOPE Approx.
	STEEL		ALUMINUM		A (min)	B (max)	H (min)	L (±2")	W (max)	
	INCHES	GAGE	INCHES	GAGE						
12	0.064	16	0.060	16	5	7	6	21	44	2¼
15	0.064	16	0.060	16	6	8	6	26	52	2¼
18	0.064	16	0.060	16	7	10	6	31	58	2½
21	0.064	16	0.060	16	8	12	6	36	66	2½
24	0.064	16	0.060	16	9	13	6	41	72	2½
30	0.079	14	0.075	14	11	16	8	51	88	2½
36	0.079	14	0.075	14	13	19	9	60	105	2
42	0.109	12	0.105	12	15	25	10	69	122	2½
48	0.109	12	0.105	12	17	29	12	78	131	2
54	0.109	12	0.105	12	17	33	12	84	143	2
60	0.109	12	0.105	12	17	36	12	87	157	1⅞
66	0.109	12	0.105	12	17	39	12	87	162	1⅞
72	0.109	12	0.105	12	17	44	12	87	169	1½
78	0.109	12	0.105	12	17	48	12	87	178	1⅜
84	0.109	12	0.105	12	17	52	12	87	184	1⅓
90	0.109	12	0.105	12	17	58	12	87	188	1¼
96	0.109	12	0.105	12	17	58	12	87	197	1⅞

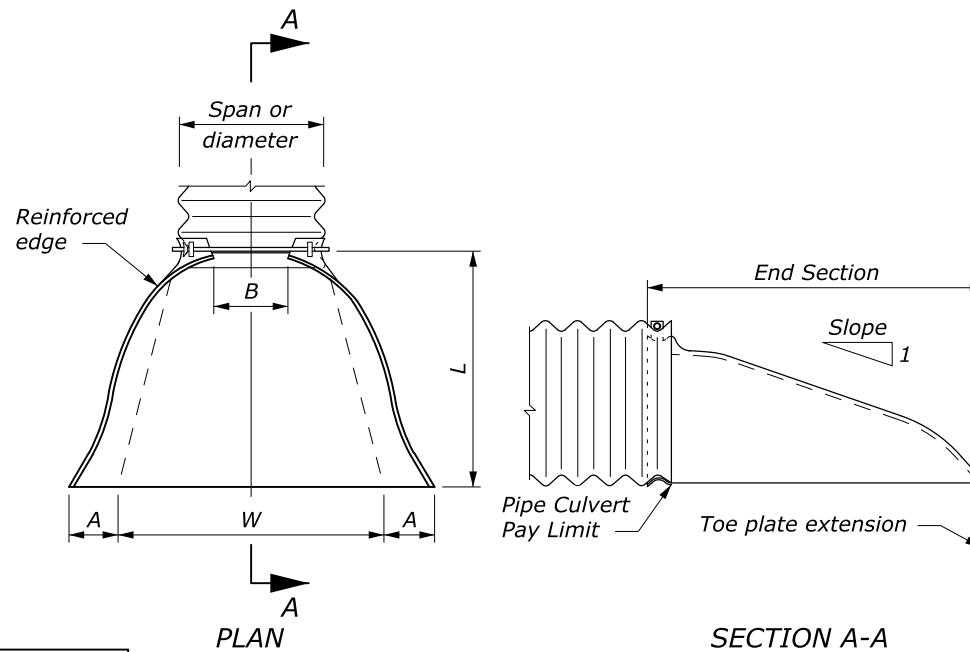

ROUND OR PIPE ARCH CULVERT

PIPE SIZE SPAN × RISE INCHES	EQUI- VALENT DIAM. (INCHES)	METAL THICKNESS				DIMENSIONS INCHES					SLOPE Approx.
		STEEL		ALUMINUM		A (min)	B (max)	H (min)	L (±2")	W (max)	
		INCHES	GAGE	INCHES	GAGE						
17 × 13	15	0.064	16	0.060	16	7	9	6	19	30	2½
21 × 15	18	0.064	16	0.060	16	7	10	6	23	36	2½
24 × 18	21	0.064	16	0.060	16	8	12	6	28	42	2½
28 × 20	24	0.064	16	0.060	16	9	14	6	32	48	2½
35 × 24	30	0.079	14	0.075	14	10	16	8	39	60	2½
42 × 29	36	0.079	14	0.075	14	12	18	9	46	75	2½
49 × 33	42	0.109	12	0.105	12	13	21	12	53	85	2½
57 × 38	48	0.109	12	0.105	12	18	26	12	63	90	2½
60 × 46	54	0.109	12	0.105	12	18	34	12	70	102	2
64 × 43	54	0.109	12	0.105	12	18	30	12	70	102	2
66 × 51	60	0.109	12	0.105	12	18	33	12	77	116	1½
71 × 47	60	0.109	12	0.105	12	18	33	12	77	114	1½
73 × 55	66	0.109	12	0.105	12	18	36	12	77	126	1½
77 × 52	66	0.109	12	0.105	12	18	36	12	77	126	1½
81 × 59	72	0.109	12	0.105	12	18	39	12	77	138	1½
83 × 57	72	0.109	12	0.105	12	18	39	12	77	138	1½
87 × 63	78	0.109	12	0.105	12	20	38	12	77	148	1½
95 × 67	84	0.109	12	0.105	12	20	34	12	87	162	1½
103 × 71	90	0.109	12	0.105	12	20	38	12	87	174	1½
112 × 75	96	0.109	12	0.105	12	20	40	12	87	174	1½

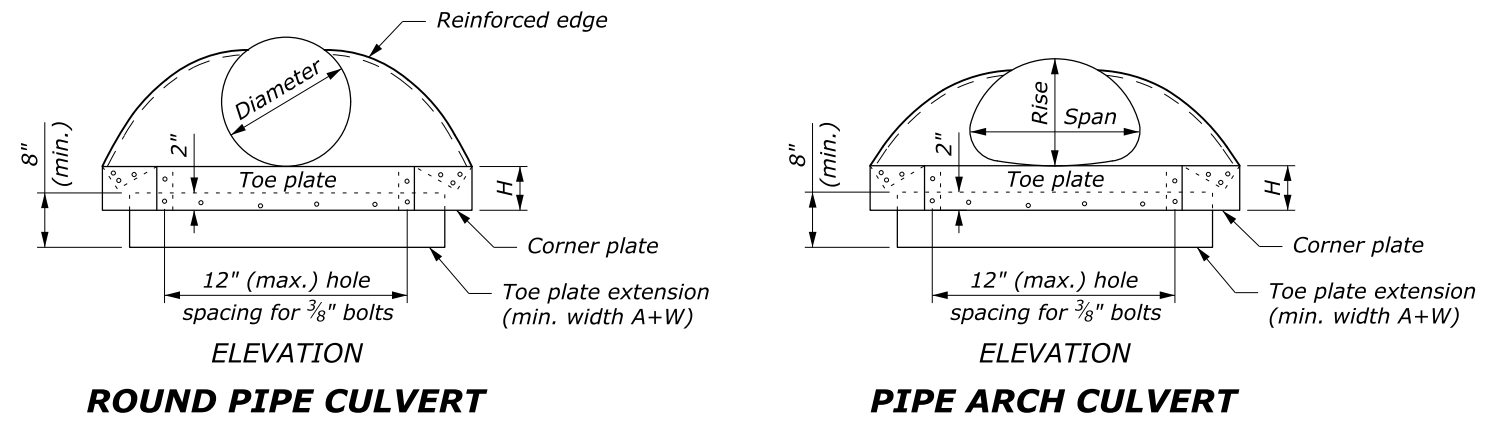

ROUND PIPE CULVERT

PIPE ARCH CULVERT

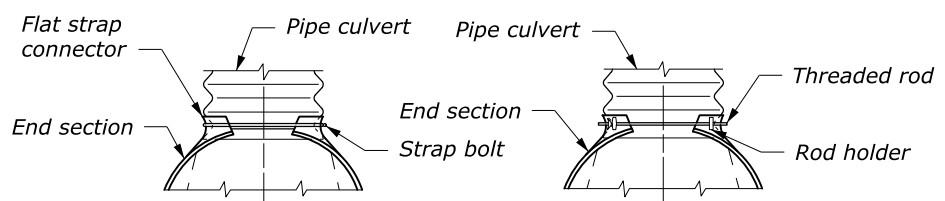

For 12" thru 24" round pipe and 17" × 13" thru 28" × 20" pipe arch
 For 30" thru 60" round pipe and 35" × 24" thru 66" × 51" pipe arch

DESIGN A CONNECTION TO ANNULAR CORRUGATED METAL PIPE

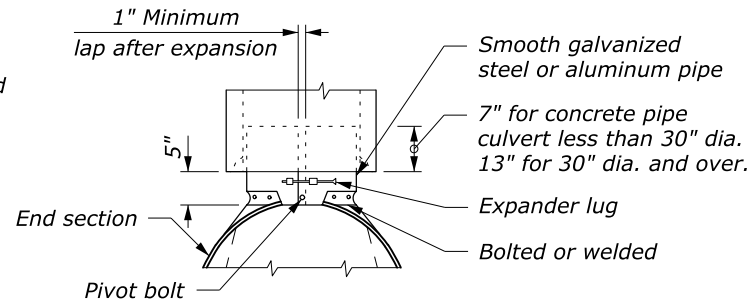

DESIGN B CONNECTION TO CONCRETE PIPE INLET END

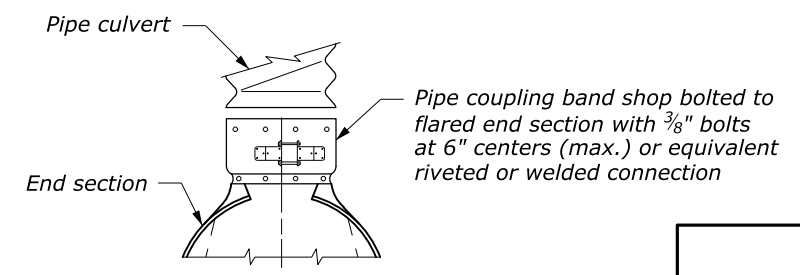

DESIGN C CONNECTION TO METAL PIPE OR OUTLET END OF CONCRETE PIPE

NO SCALE

NOTES:

- Variations in design and dimensions are permitted to allow for manufacturer's standards.
- Fabricate the diameter of the end section of Design B to match the inside diameter of the concrete pipe culvert.
- Design C may be used in lieu of design A for all metal pipe culvert sizes. Coupling bands may be any acceptable type for the pipe culvert specified.
- Fabricate multiple piece bodies with lap seams tightly joined by 3/8-inch rivets or bolts. Fabricate end section center panels for 60-inch and larger diameter pipe and equivalent pipe arch from 0.138-inch steel or 0.135-inch aluminum.
- On end section center panels for 66-inch and larger equivalent pipe arch, provide 2½-by 2½-by ¼-inch angle reinforcement bolted or riveted under the center panel seam.
- Supplement the reinforcement edges of end sections for 60-inch and larger diameter pipe and 66-inch and larger equivalent pipe arch with 2½-by 2½-by ¼-inch stiffener angles attached with bolts or rivets.
- Fabricate connector section, corner plate and toe plate extensions from the same metal thickness as the panel body. Use toe plate extension where shown in the plans.
- Warp embankment slopes to match the slope of the flared end sections.

M:\PROJECTS\COLLABORATION\Louisville\02172021_Details_Work\st60204_EFL_TEMP.dgn [Sheet] 18 February 2021 10:32 AM