

16-INCH DEPTH
(MOUNTABLE)

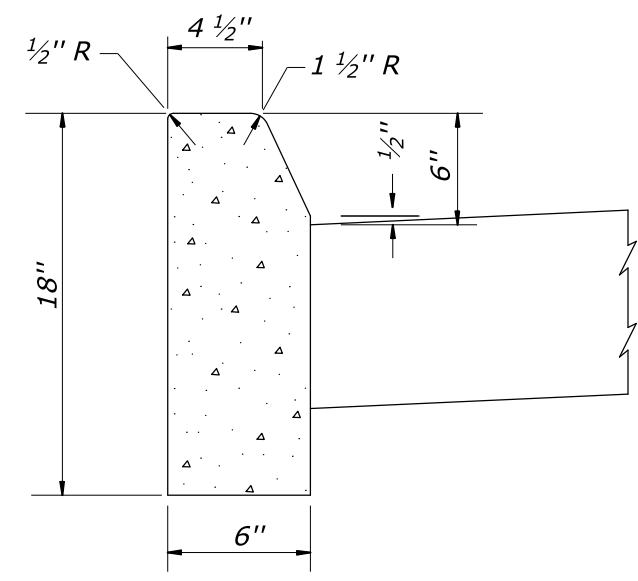

18-INCH DEPTH
(NON-MOUNTABLE)

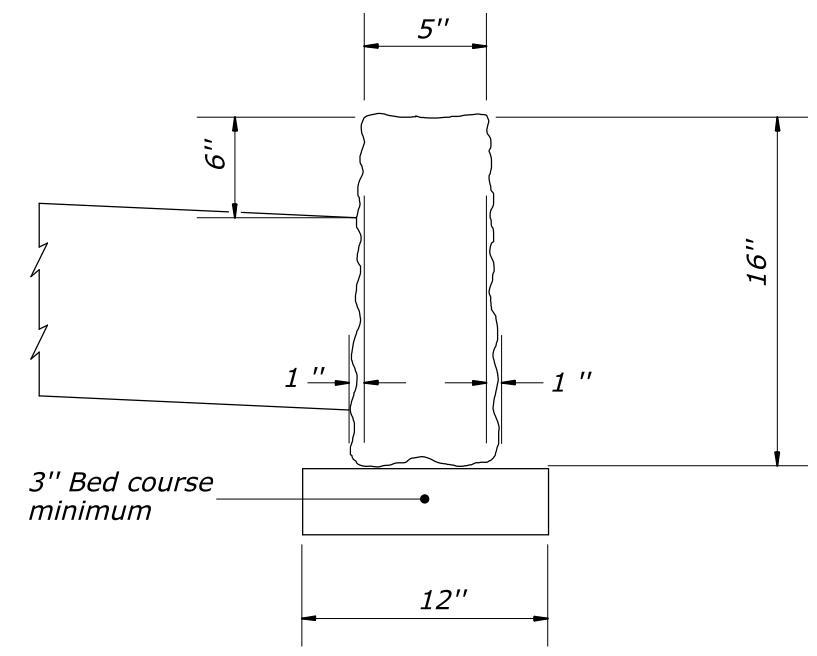

STONE CURB
16-INCH DEPTH
(NON-MOUNTABLE)

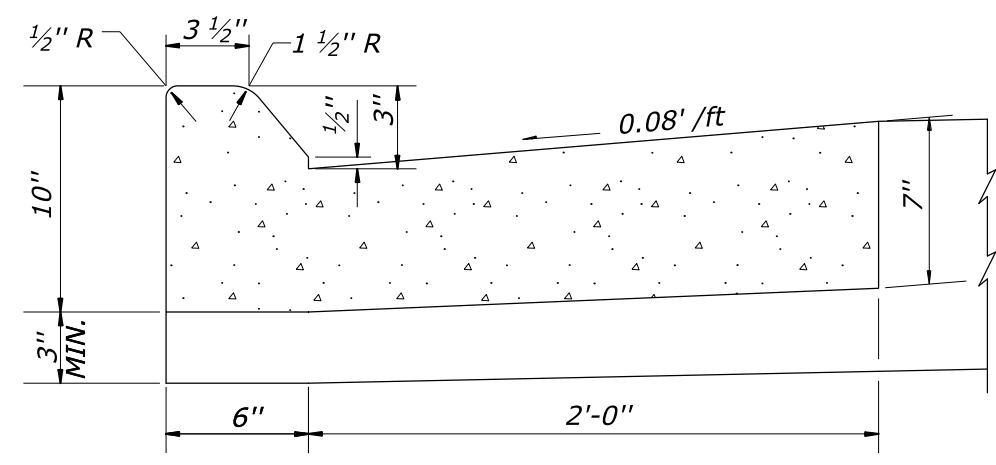

10-INCH DEPTH
(MOUNTABLE)

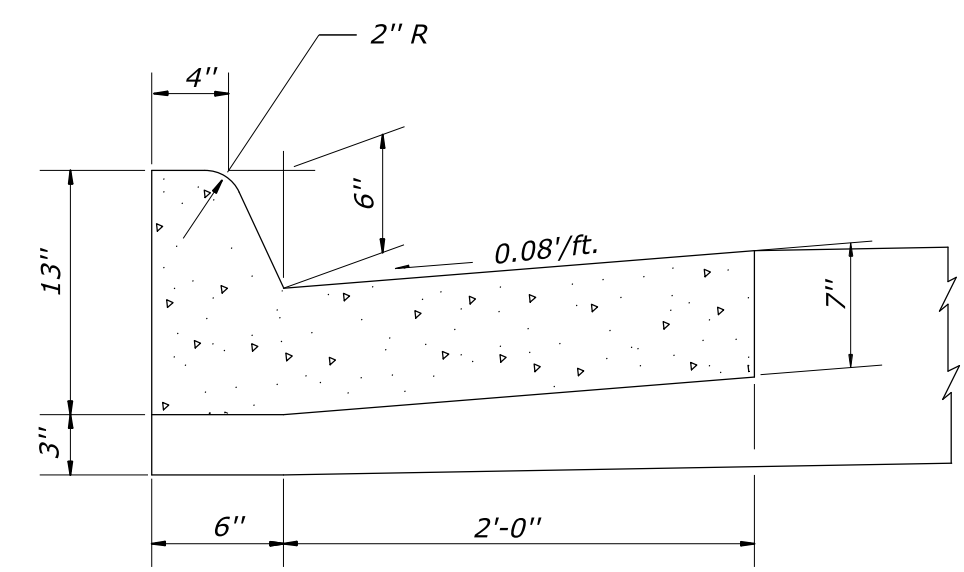

13-INCH DEPTH
(NON-MOUNTABLE)

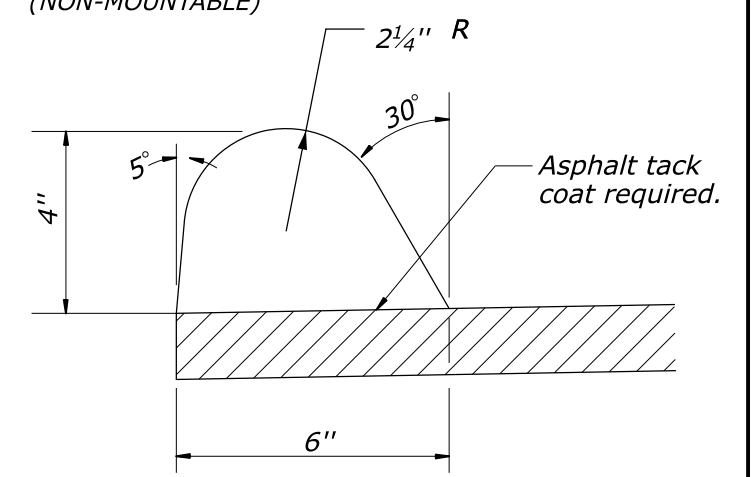

ASPHALT CONCRETE CURB
4-INCH DEPTH
(NON-MOUNTABLE)

Asphalt tack coat may be rapid curing liquid asphalt or emulsified asphalt.

PORTLAND CEMENT CONCRETE CURB

PORTLAND CEMENT CONCRETE CURB AND GUTTER

U.S. DEPARTMENT OF TRANSPORTATION FEDERAL HIGHWAY ADMINISTRATION OFFICE OF FEDERAL LANDS HIGHWAY	
EFLHD DETAIL	
CURBS	
DETAIL APPROVED FOR USE	DETAIL
APPROVED: MAY 2011	E609-01
REVISED: SEPTEMBER 2020	

NO SCALE