

ELEVATION

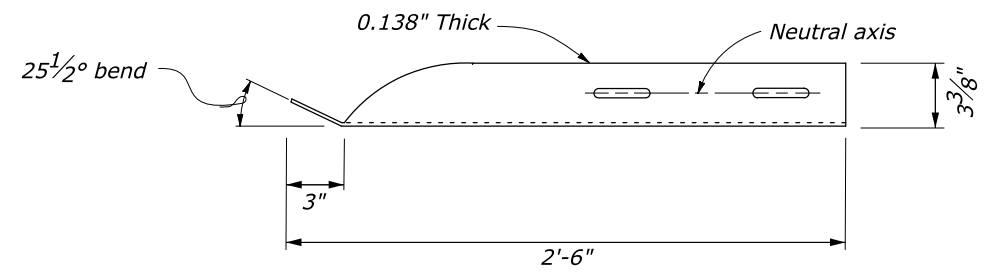

PLAN

TERMINAL CONNECTOR ARTBA RE-8-79

ANCHOR PLATE DETAILS FOR BCT AND MELT ANCHORAGE ASSEMBLY ARTBA RE-71-79

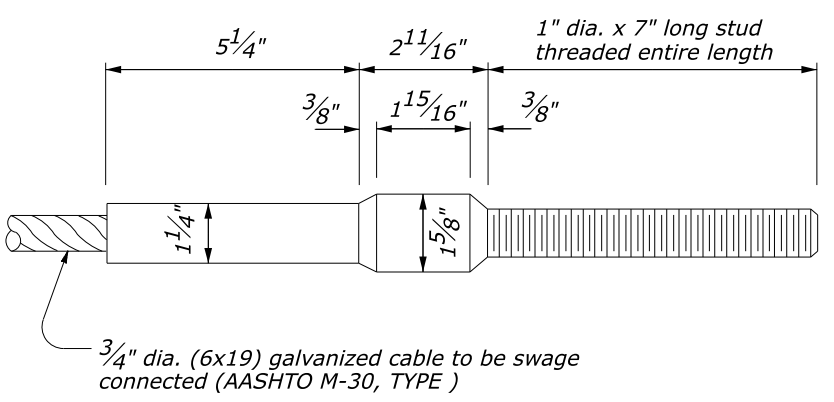

Standard swaged fitting

CABLE ASSEMBLY ARTBA F-37-76

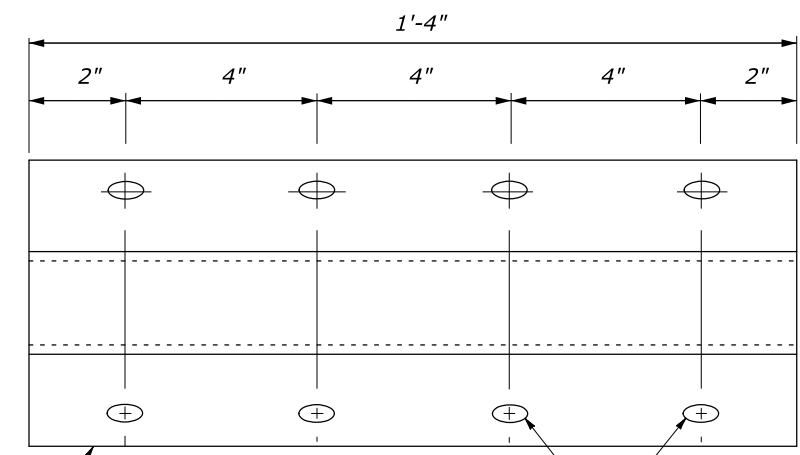

Bent Plate 3/16" thickness

ANCHOR PLATE ARTBA RE-71-79

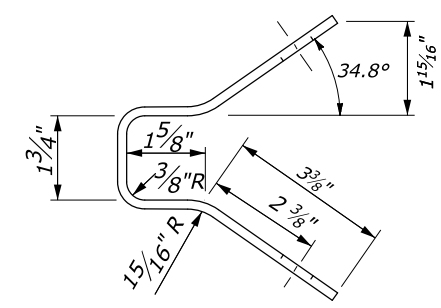

NO SCALE

U.S. DEPARTMENT OF TRANSPORTATION FEDERAL HIGHWAY ADMINISTRATION OFFICE OF FEDERAL LANDS HIGHWAY	
EFLHD DETAIL	
G4 W-BEAM GUARDRAIL BCT AND MELT ANCHORAGE ASSEMBLY	
DETAIL APPROVED FOR USE APPROVED: MAY 2011 REVISED: SEPTEMBER 2020	DETAIL E617-13

M:\PROJECTS\COLLABORATION\Ouhssayne_02172021_Details_Workst61713_detail.dgn [Sheet] 18 February 2021 1:07 PM