

PLAN

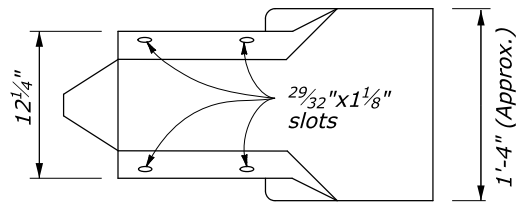

ELEVATION

\*This dimension is 7 1/2" in RE-7-79. If the same dimension is used in this part, it will give an acceptable overall length (\*\*\*) of approximately 2'-1 1/2" .

**ROUND END SECTION  
ARTBA RE-6-79**

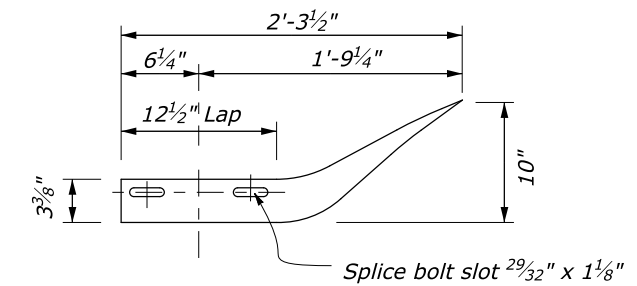

PLAN

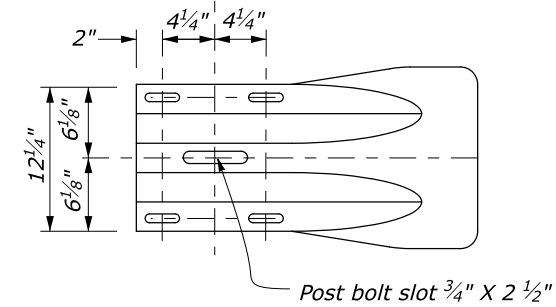

ELEVATION

**FLARED END SECTION  
ARTBA RE-5-76**

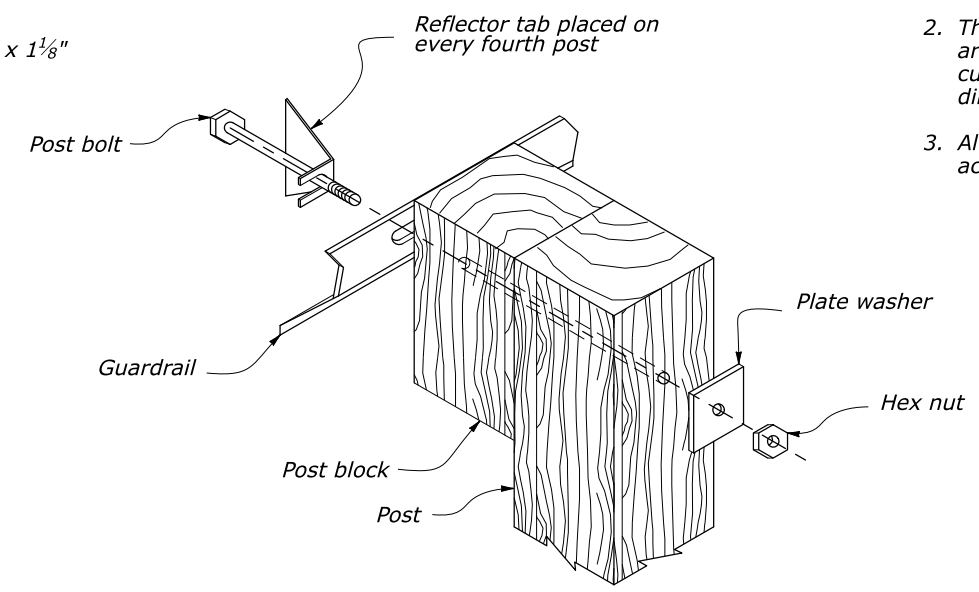

**SYSTEM ASSEMBLY**

**NOTES:**

1. Rounded or flared end sections are acceptable alternates to buffered end sections and type 1 end sections on terminal sections at the trailing ends of guardrail runs on the right side of multilane roadways and where shown in the plans on the left side of multilane roadways as approved by the CO.
2. The curb and curb and gutter shapes are shown for illustration only. Use actual curb and curb and gutter shapes and dimensions as shown in the plans.
3. Alternate reflector tab shapes are acceptable as approved by the CO.

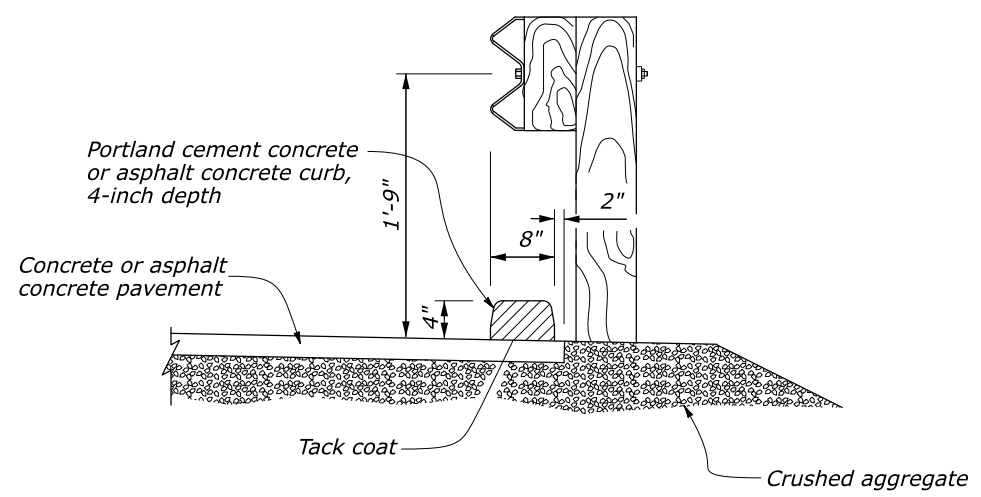

**PLACEMENT OF GUARDRAIL  
AT CURB LOCATIONS**

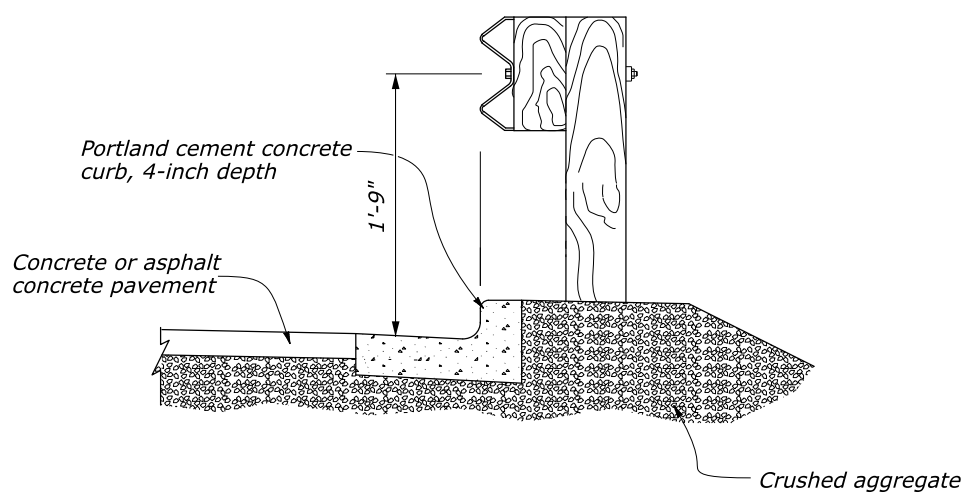

**PLACEMENT OF GUARDRAIL  
AT CURB AND GUTTER LOCATIONS**

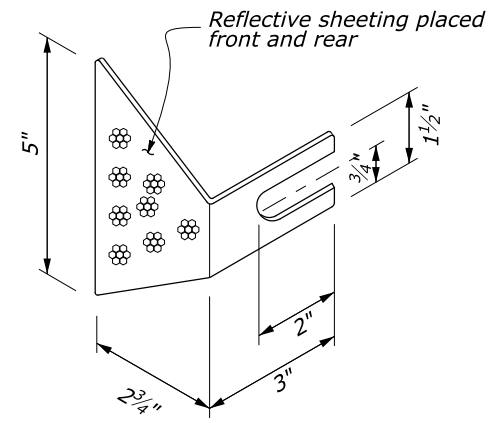

**REFLECTOR TAB**

NO SCALE

U.S. DEPARTMENT OF TRANSPORTATION FEDERAL HIGHWAY ADMINISTRATION OFFICE OF FEDERAL LANDS HIGHWAY	
EFLHD DETAIL	
<b>G4 W-BEAM GUARDRAIL SUPPLEMENT INSTALLATIONS</b>	
DETAIL APPROVED FOR USE APPROVED: MAY 2011 REVISED: SEPTEMBER 2020	DETAIL E617-23