

WOOD POST DATA TABLE		
POST SIZE	HOLE DIAMETER	(D) (MIN.)
4" x 4"	Not Required	3'
4" x 6"	1.5"	4'
6" x 6"	2"	4'

**NOTES:**

1. Breakaway sign support is not required for signs placed behind protective barriers.
2. Signs requiring 6-inch by 6-inch wood posts are considered to be non-breakaway if multiple posts are required and posts cannot be spaced a minimum of 7 feet apart.
3. Place non-breakaway signs outside the clear zone or shield with approved barrier. Do not place holes in posts of non-breakaway signs.
4. Position splice overlap on U-channel steel posts entirely between the ground line and 18 inches above the ground line. Do not place more than one splice per post.
5. Attach the square tubular steel post to the anchor with a corner bolt according to the manufacturer's recommendations. Size the anchor according to the manufacturer's recommendations to accept the post size specified.
6. Maintain the post assembly in a plumb position.
7. For sign punching details, see the blank standards in the "Standard Highway Signs and Markings" as specified in the latest edition of the MUTCD.
8. Refer to Detail E633-01 for sign mounting details.
9. Refer to Detail E633-04 for sign bracing details.
10. Refer to Section 2A.21 of the MUTCD, latest edition, for additional information.

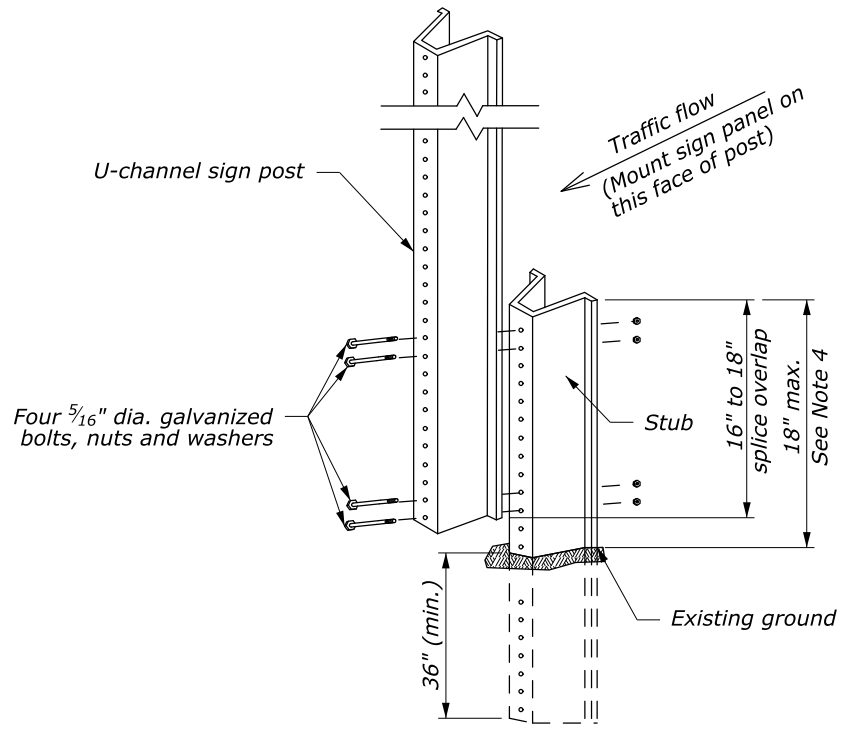

U-CHANNEL STEEL POST

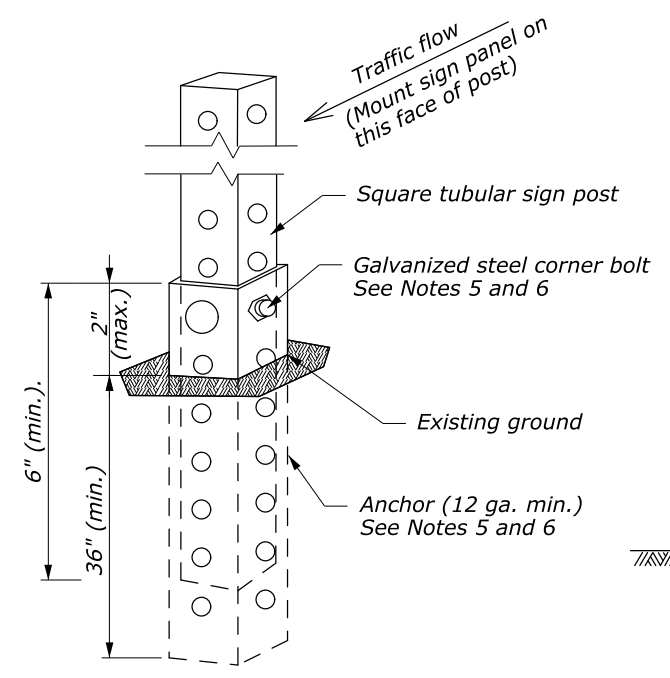

SQUARE TUBULAR STEEL POST

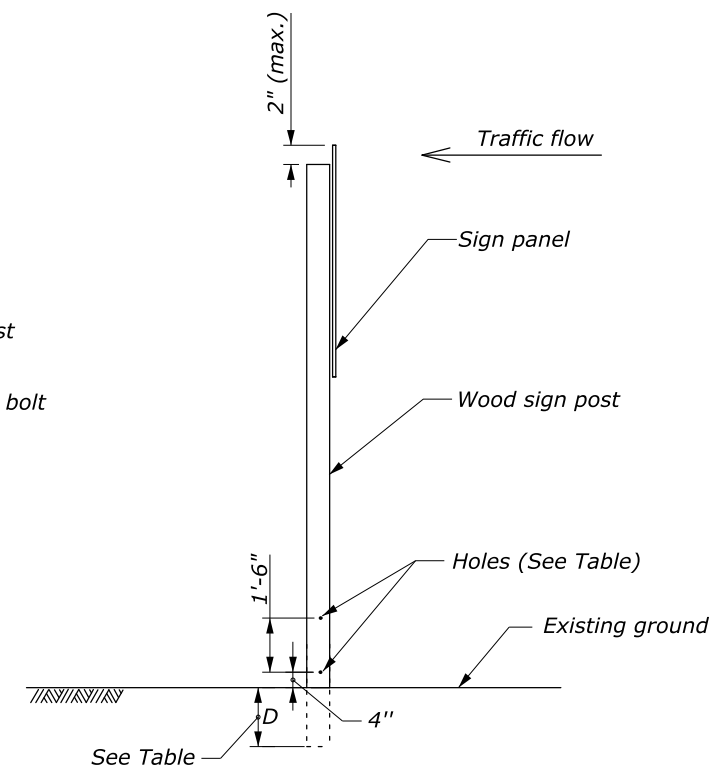

WOOD POST

**BREAKAWAY SIGN SUPPORT**

M:\Standards\_and\_Details\EFLHD\_Detail-Drawings\FP-14\FP-14\_ORD\_Version\ORD\_Ready\Section-633\_Permanent Traffic Control\63303\_detail.dgn [Sheet] 4 March 2021 9:25 AM

NO SCALE

U.S. DEPARTMENT OF TRANSPORTATION FEDERAL HIGHWAY ADMINISTRATION OFFICE OF FEDERAL LANDS HIGHWAY	
EFLHD DETAIL	
<b>BREAKAWAY SIGN SUPPORT WOOD AND STEEL POSTS</b>	
DETAIL APPROVED FOR USE APPROVED: MAY 2011 REVISED: SEPTEMBER 2020	DETAIL E633-03



## NOTES TO THE DESIGNER

January 16, 2019

---

### General Information

1. *If any of Details E633-02, -03, -04, or -05 is used, also include Detail E633-01.*
2. *For Breakaway Sign Supports, use Detail E633-02 for Corrosion Resistant Steel and use Detail E633-03 for Wood and Steel.*
3. *For sign bracings if needed, use Detail E633-04 (Sign bracings are usually needed for signs with 48" width or greater). Verify with Safety, COE and Partner Agency if bracings are required.*
4. *For "Folding Signs" use Detail E633-05.*
5. *Project Specific Details should be created for NPS UniGuide sign systems.*

---

### Applicable SCRs.

1. Section 633 PERMANENT TRAFFIC CONTROL.  
Make sure to specify the post materials (See FP 633.01 for designated posts materials: wood, aluminum, galvanized steel, or corrosion resistant steel) in the plans (typically on Summaries and Schedules sheets), in the sign pay item name, or in the SCR.

---

### Typical Pay Item Used

- 63305-0100 thru 63305-1600 Posts, steel (Different sizes/shapes) (LNFT)
- 63305-1700 thru 63305-2000 Posts, wood (Different sizes) (LNFT)
- 63306-0100 thru 63306-1600 Posts, steel (Different sizes/shapes) (Each)
- 63306-1700 thru 63306-2000 Posts, wood (Different sizes) (EACH)
  
- 63319-0000 Post sleeve (EACH)

---

### Updates

- 01/2019 – Updated "General Information" due to Details updates.  
09/2020 - Revised the applicable SCRs section to not refer to LOS (There are no 633 LOS in the library yet).