

**TYPE - 4A**

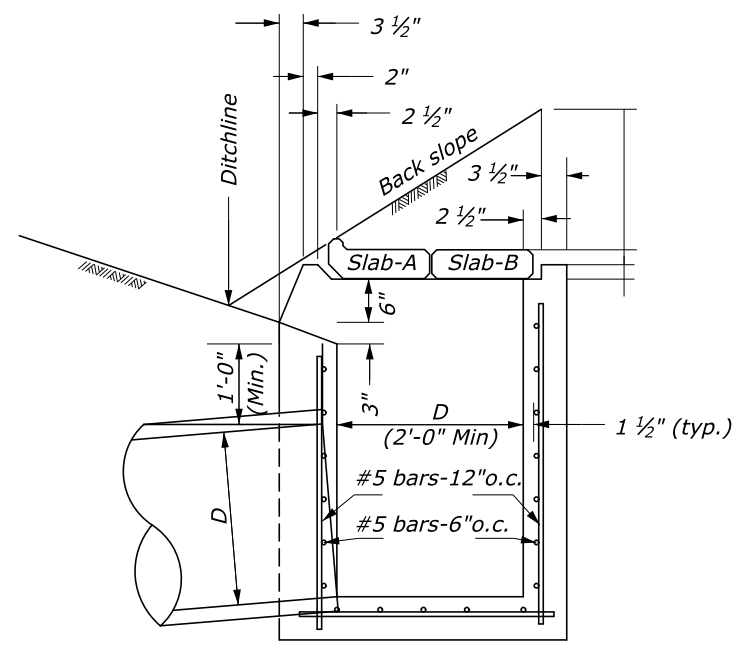

**TYPE - 4B**

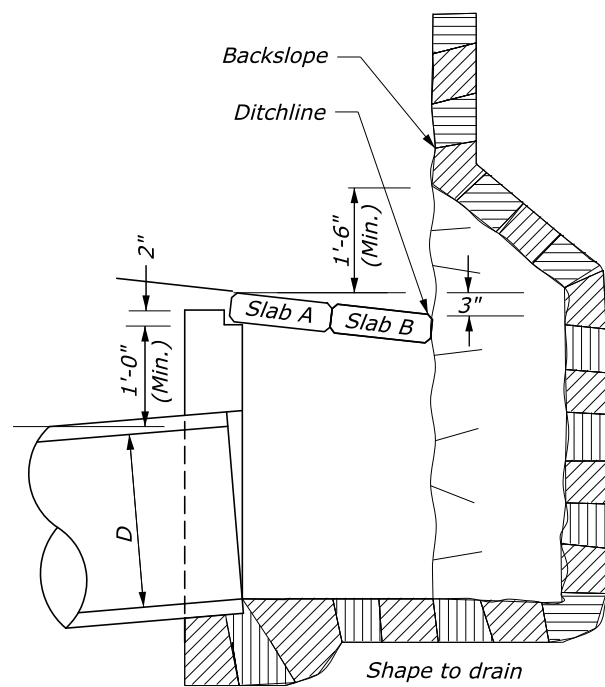

**TYPE - 4C**

Note:  
In rock without backwall or floor.  
Reinforce same as Type 4A

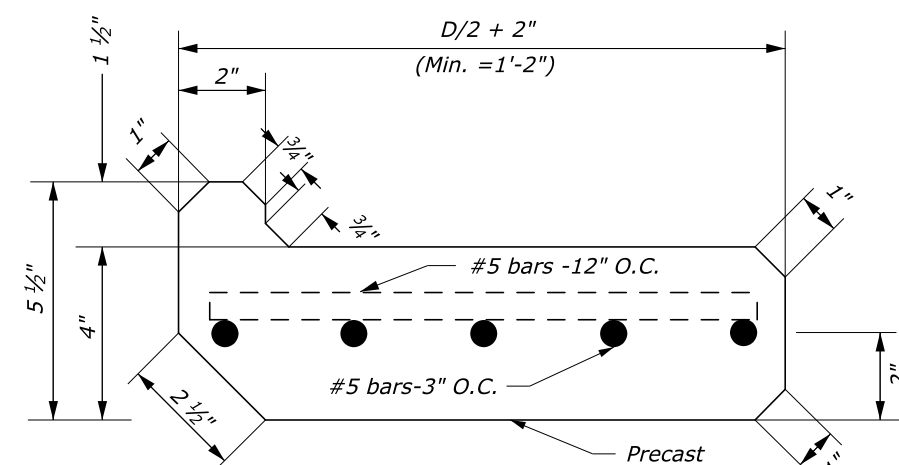

**SLAB-A**

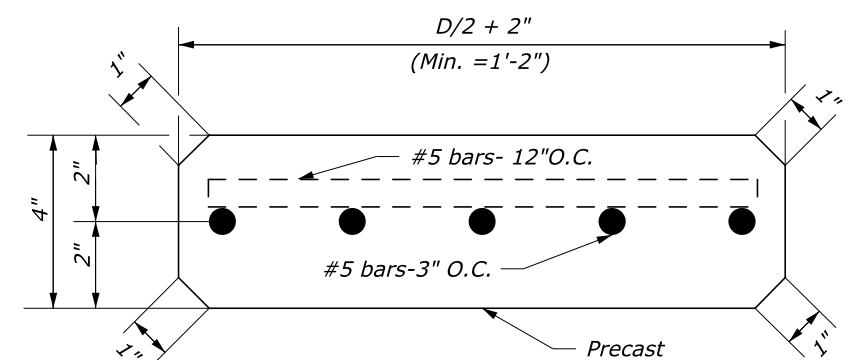

**SLAB-B**

**NOTES:**

1. At the option of the Contractor, walls less than 4 feet deep may be of concrete or concrete block.
2. Inlets to be parallel to roadway centerline and grade. For pipes on skew, adjust inlets as directed.
3. Ditch or paved waterways to be warped and widened near inlets as directed by the CO, to facilitate drainage and to protect slopes at ends of inlets.
4. For payment purposes, one slab A plus one slab B or two slabs B constitute one concrete cover.

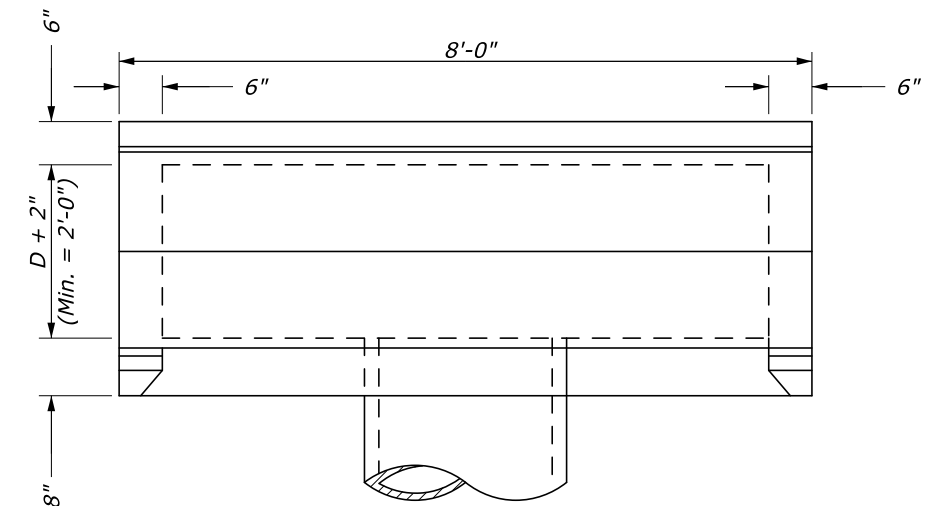

**PLAN**

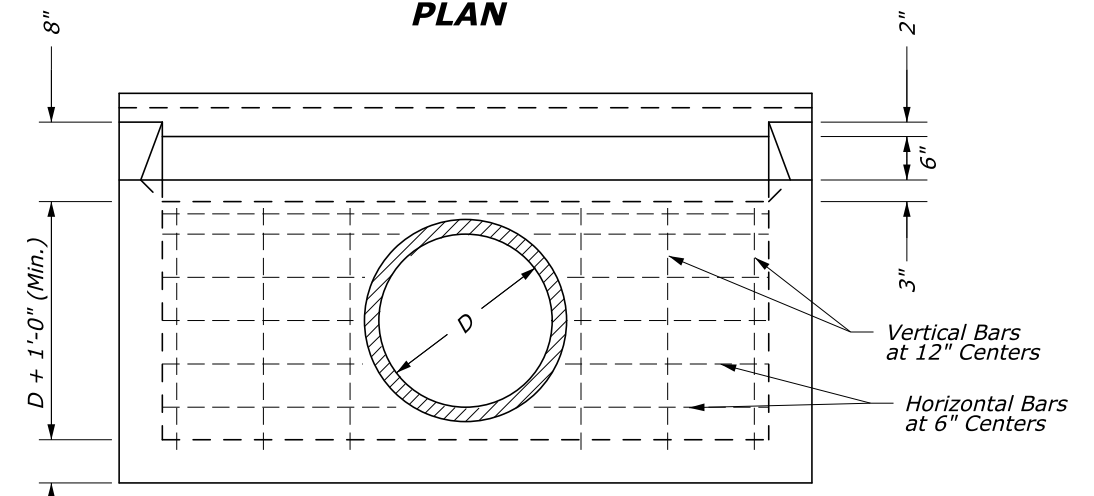

**FRONT ELEVATION**

(Type 4B, shown, other types comparable)

NO SCALE

|   |         |
|---|---------|
| U.S. DEPARTMENT OF TRANSPORTATION<br>FEDERAL HIGHWAY ADMINISTRATION<br>EASTERN FEDERAL LANDS HIGHWAY DIVISION |         |
| U.S. CUSTOMARY DETAIL   |         |
| <b>INLET, TYPE 4A, 4B, and 4C</b>   |         |
| DETAIL APPROVED FOR USE   | DETAIL  |
| APPROVED : MAY 2011   | E604-01 |

26-May-2015 10:06 AM M:\Standards\_and\_Details\EFLHD\_Detail\Drawings\FP-A\F60401\_detail.dgn