

**HERRINGBONE DRAINAGE PATTERN
(PARALLEL TO ζ)**

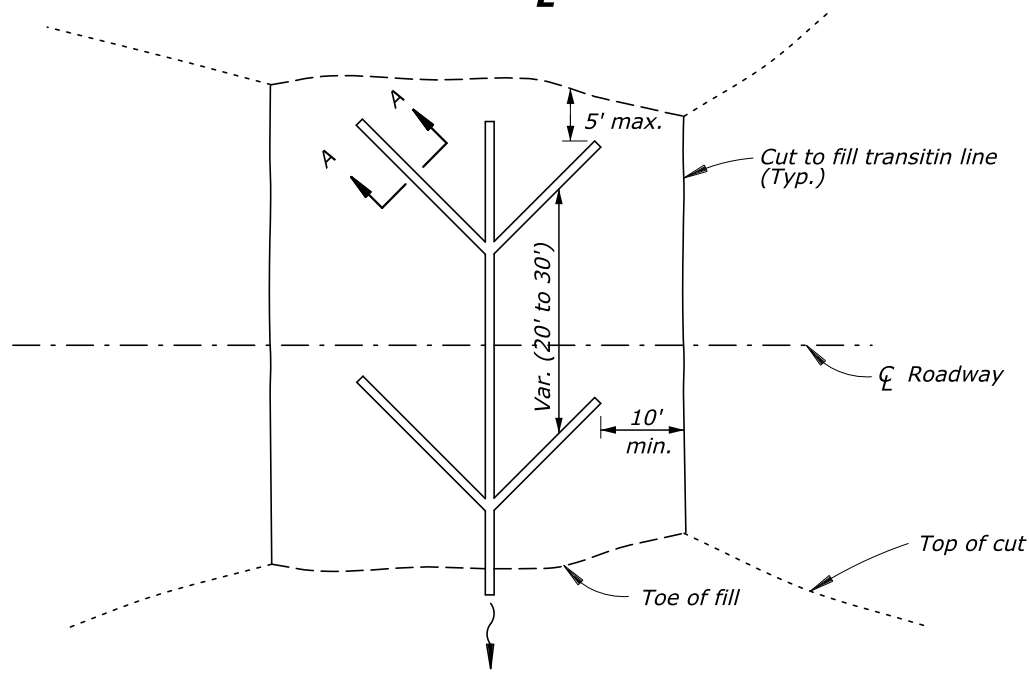

**HERRINGBONE DRAINAGE PATTERN
(PERPENDICULAR TO ζ)**

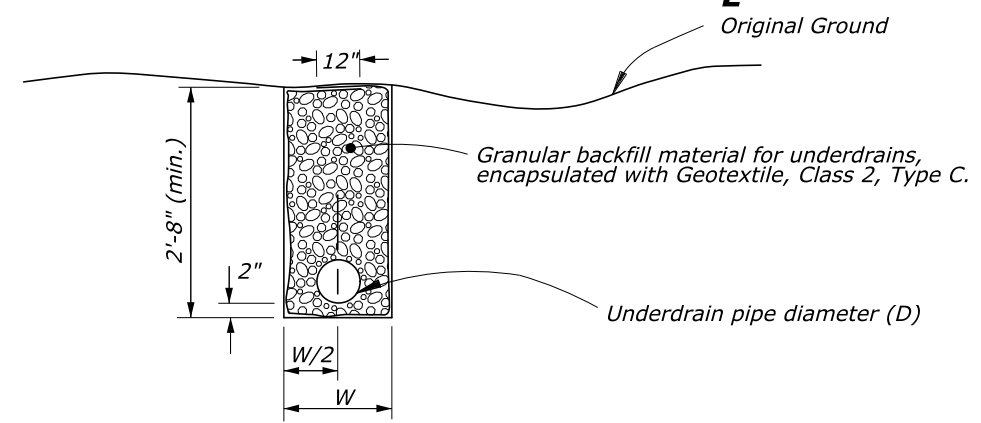

SECTION A-A

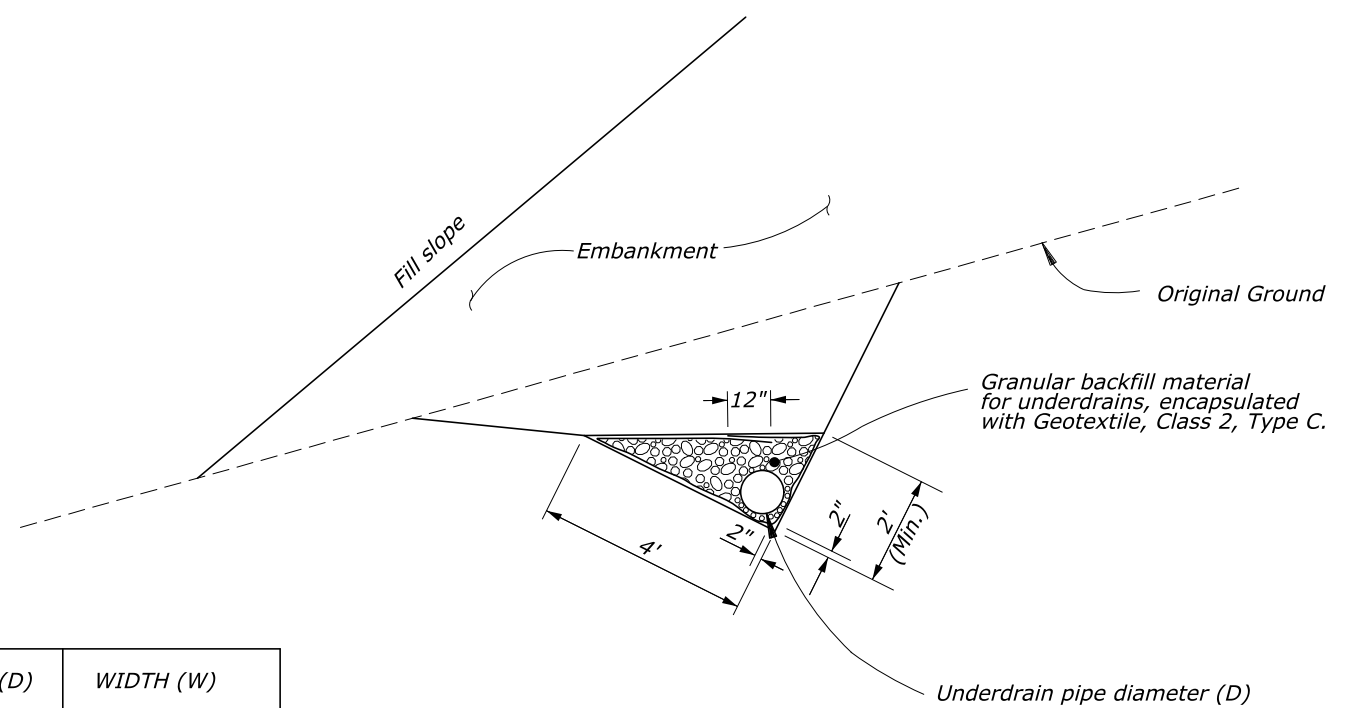
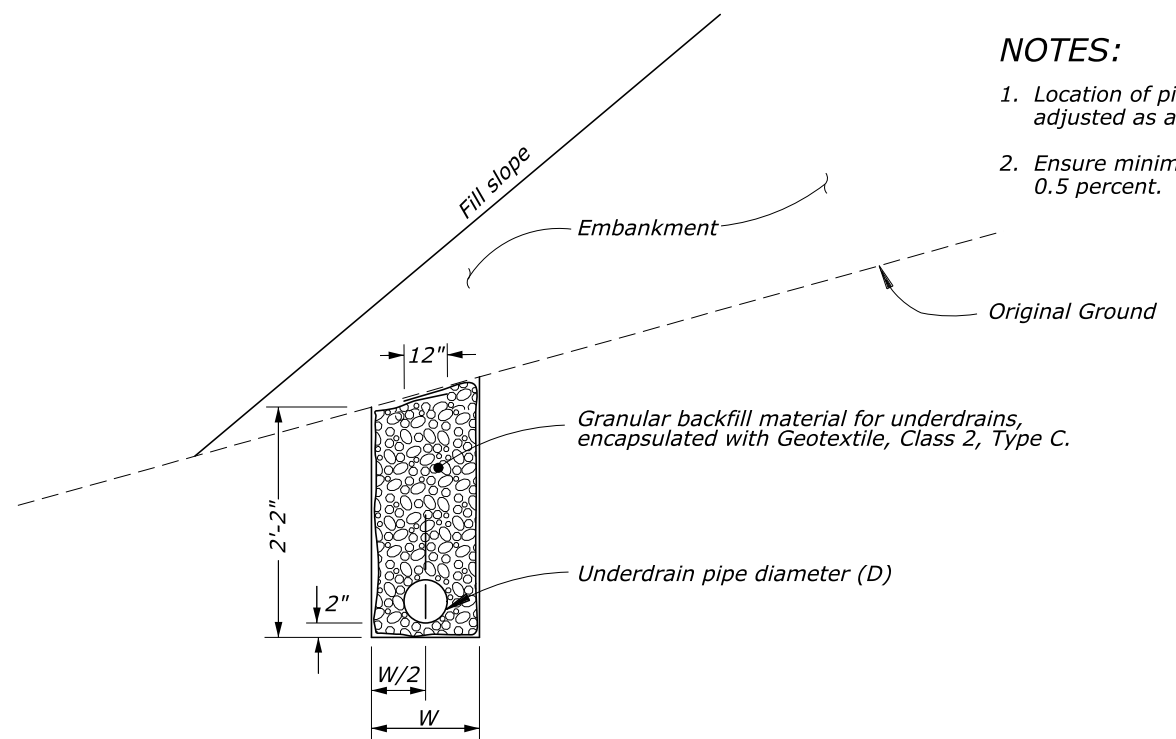

DIAMETER (D)	WIDTH (W)
4"	12"
6"	15"

NOTES:

1. Location of pipe underdrains may be adjusted as approved by the CO.
2. Ensure minimum grade of underdrain is 0.5 percent.

NO SCALE

U.S. DEPARTMENT OF TRANSPORTATION FEDERAL HIGHWAY ADMINISTRATION EASTERN FEDERAL LANDS HIGHWAY DIVISION	
U.S. CUSTOMARY DETAIL	
UNDERDRAIN, FOR FILL SLOPES	
DETAIL APPROVED FOR USE	DETAIL
APPROVED: MAY 2011 REVISED: JANUARY 2021	E605-02