

NOTE:
Place transverse expansion joints at intervals of not more than 60 feet for curbs and sidewalks.

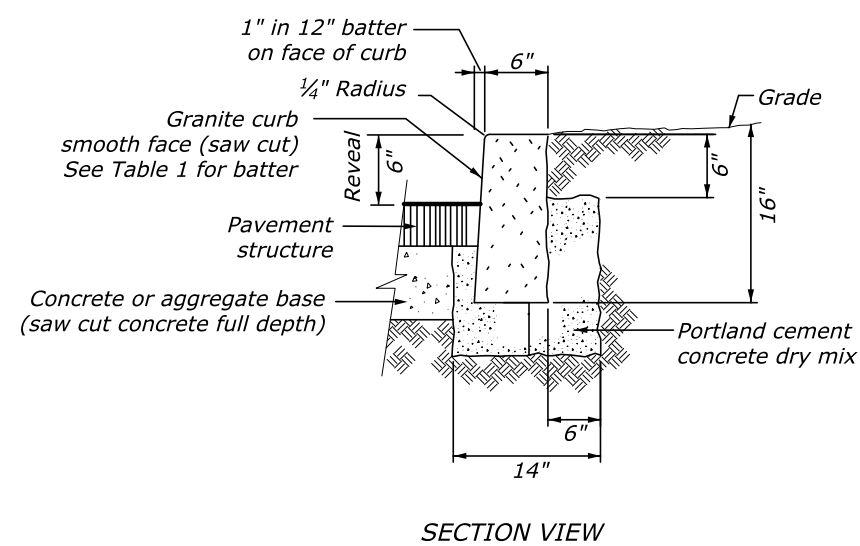

STONE CURB TYPE 1, 16" DEPTH (GRANITE TYPE A OR B) (WITHOUT SIDEWALK)

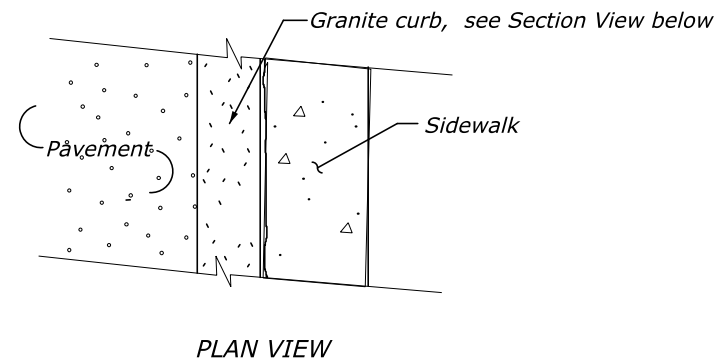
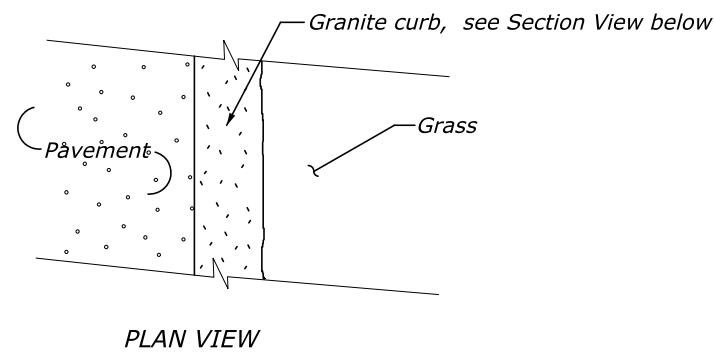
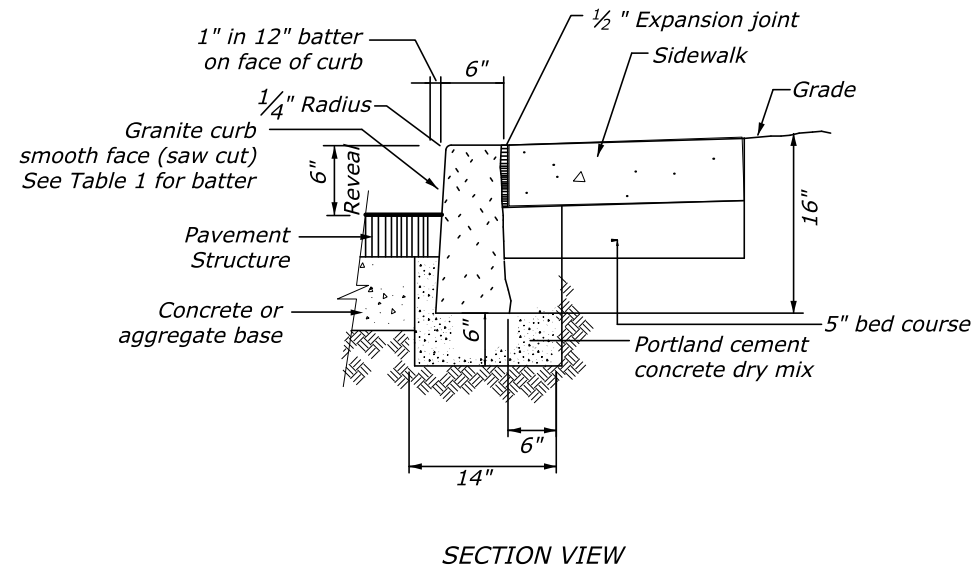

STONE CURB TYPE 1, 16" DEPTH (GRANITE TYPE A OR B) (WITH SIDEWALK)

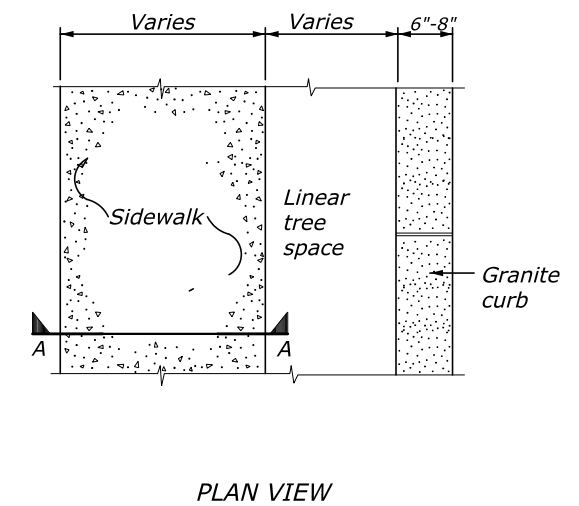

STONE CURB TYPE 1, 16" DEPTH (GRANITE TYPE A OR B) (WITH SIDEWALK AND LINEAR TREE SPACE)

TABLE 1

BATTER FOR GRANITE CURB	
TYPE	BATTER (H:V)
A	1:12
B	3/4:10

NO SCALE

U.S. DEPARTMENT OF TRANSPORTATION FEDERAL HIGHWAY ADMINISTRATION EASTERN FEDERAL LANDS HIGHWAY DIVISION	
U.S. CUSTOMARY DETAIL	
GRANITE CURB	
DETAIL APPROVED FOR USE	DETAIL
APPROVED: MAY 2011 REVISED: JANUARY 2021	E609-02