

NOTES:

1. Install copper-clad ground rod or copper plate according to Subsection 636.07.
2. Add additional lead-in cables and terminal strips as needed.

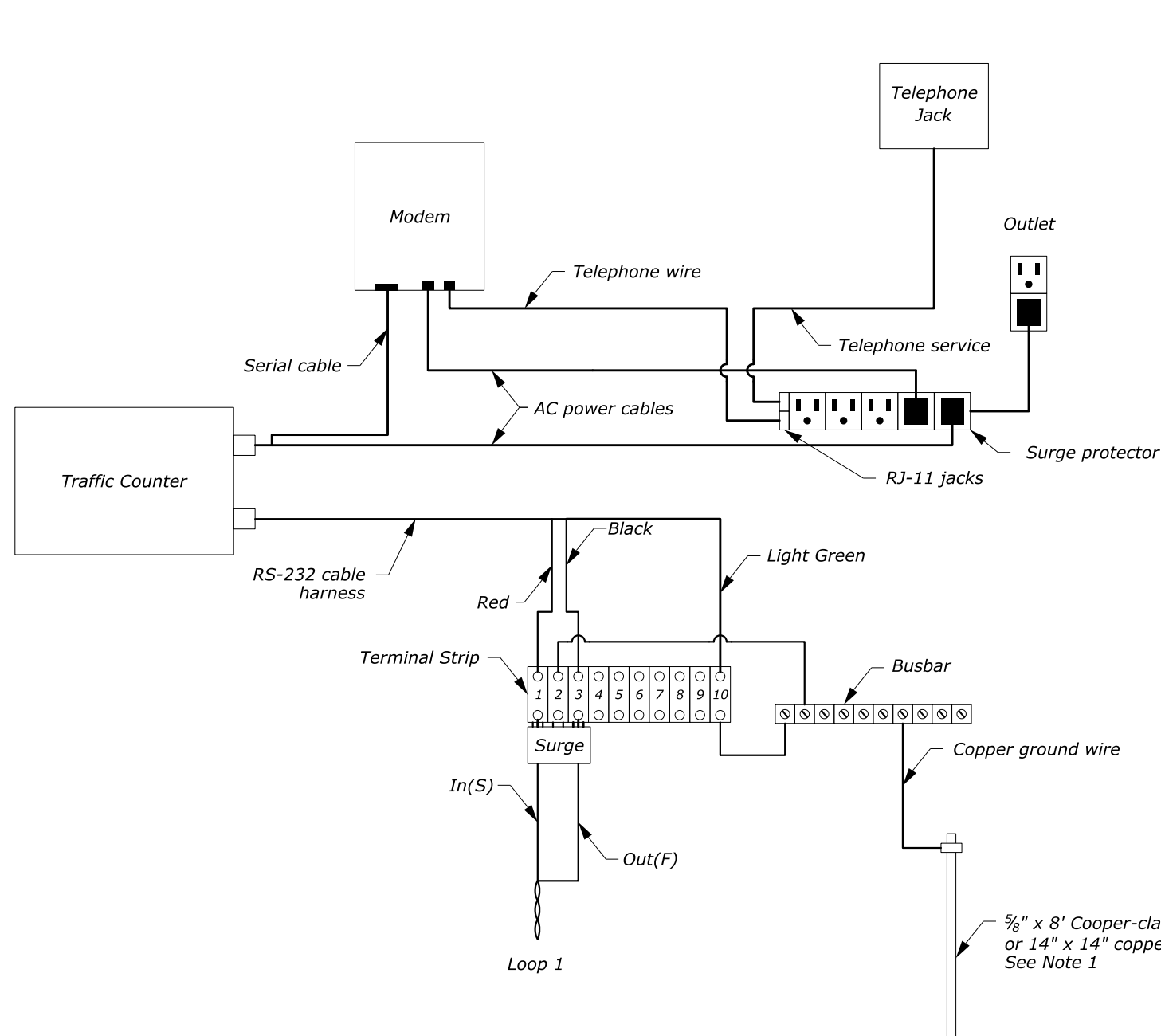

AC POWER AND MODEM

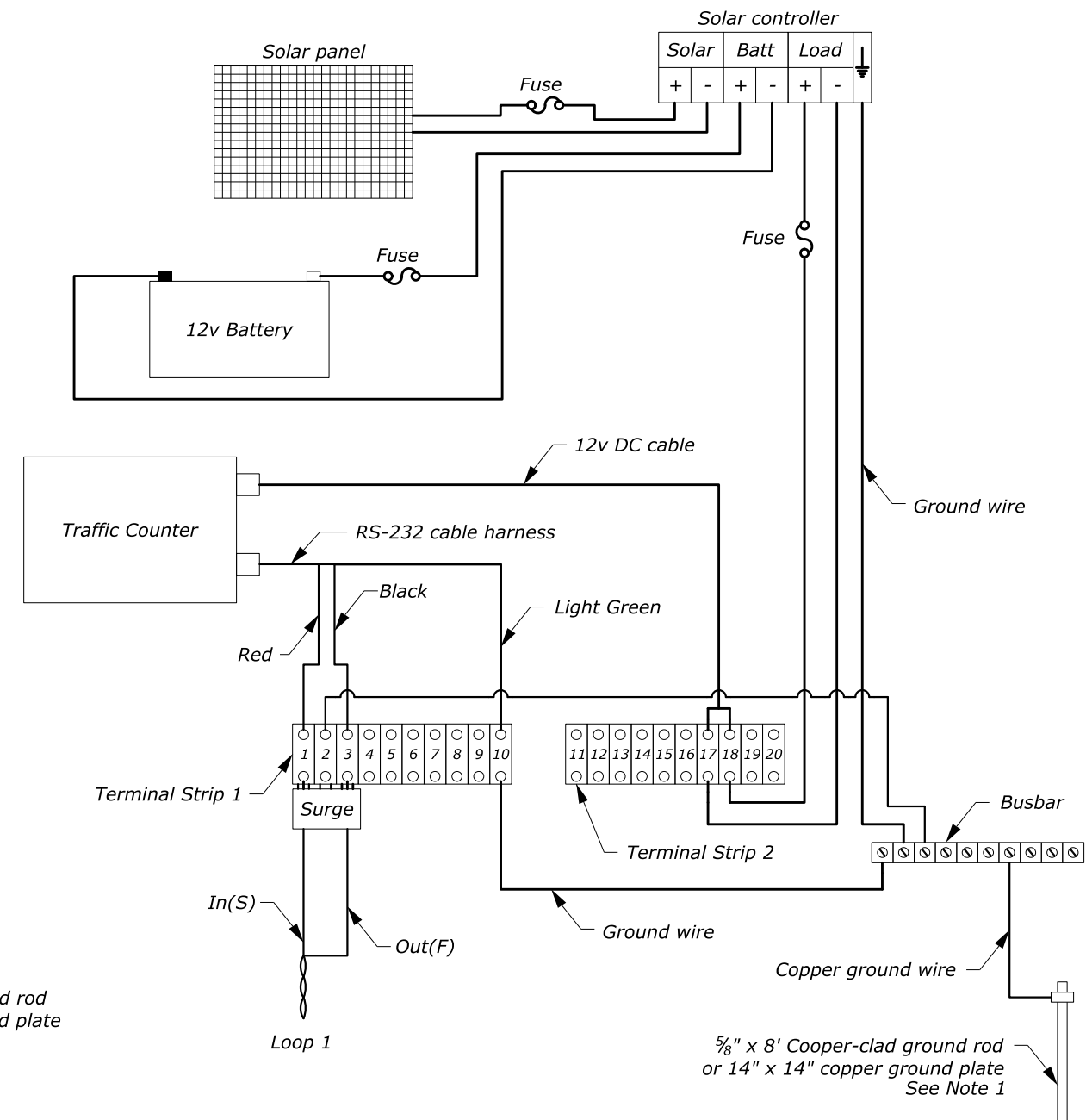

SOLAR POWER WITHOUT MODEM

24-Jan-2019 11:04 AM \$TIME\$ M:\Standards_and_Details\EFLHD_Detail\Drawings\EFLHD_Details_Lanouche\E636_details\CADD\E63608_EFL_TEMP.dgn

NO SCALE

U.S. DEPARTMENT OF TRANSPORTATION FEDERAL HIGHWAY ADMINISTRATION EASTERN FEDERAL LANDS HIGHWAY DIVISION	
U.S. CUSTOMARY DETAIL	
TRAFFIC COUNTER CABINET WIRING DIAGRAM	
REVISIONS: JANUARY 2019	DETAIL E636-08