

SECTION TRUNCATED DOME

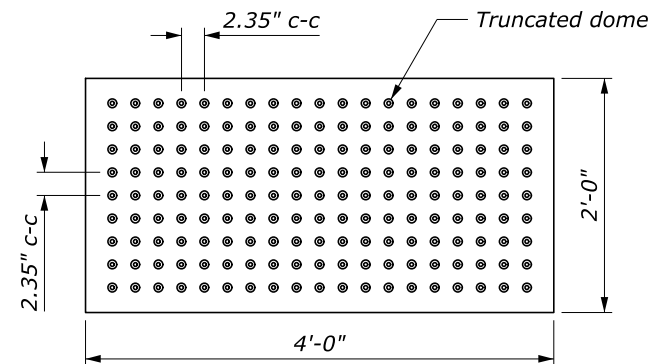

PLAN

DETECTABLE WARNING FIELD WITH TRUNCATED DOMES

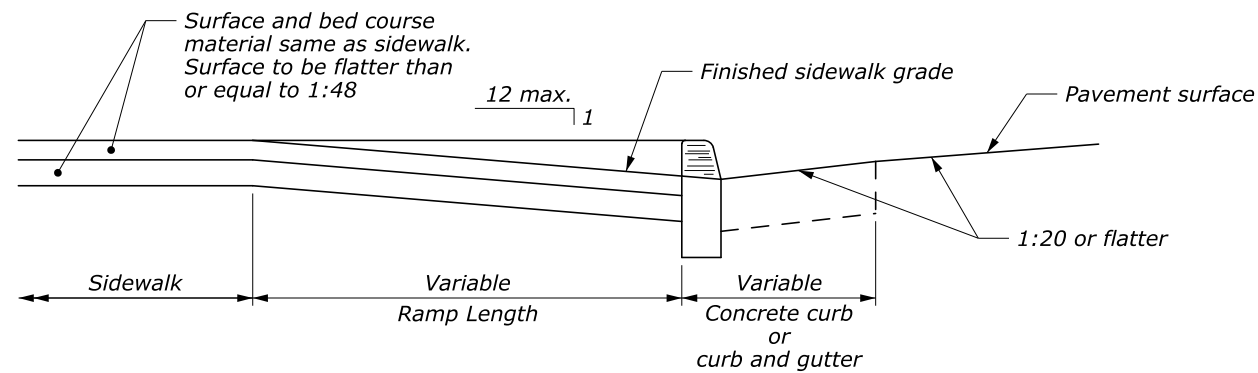

RAMP - TYPICAL SECTION

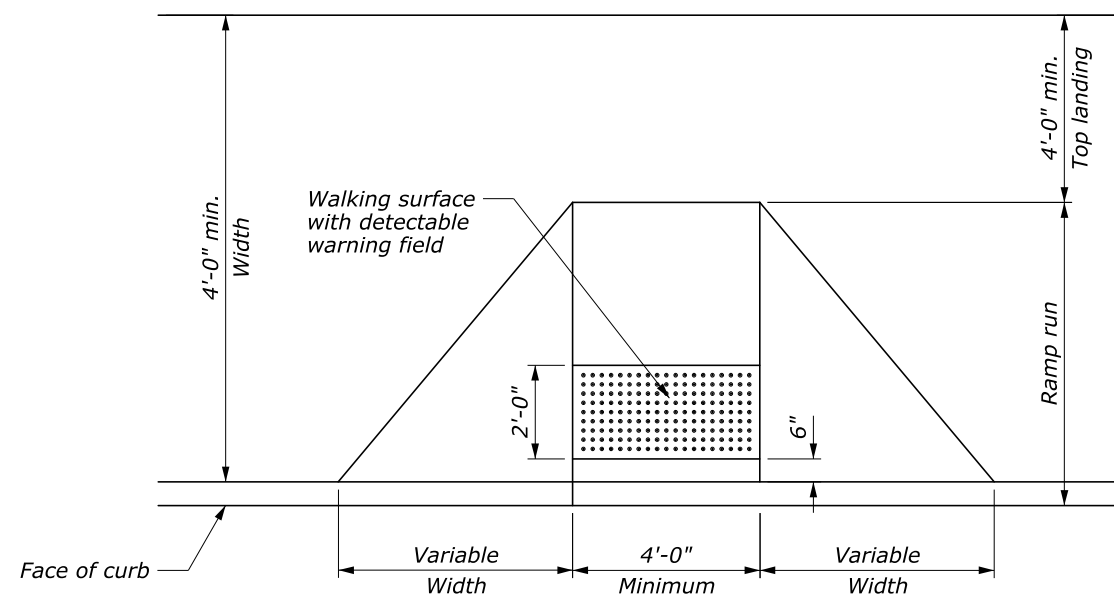

PERPENDICULAR CURB RAMP

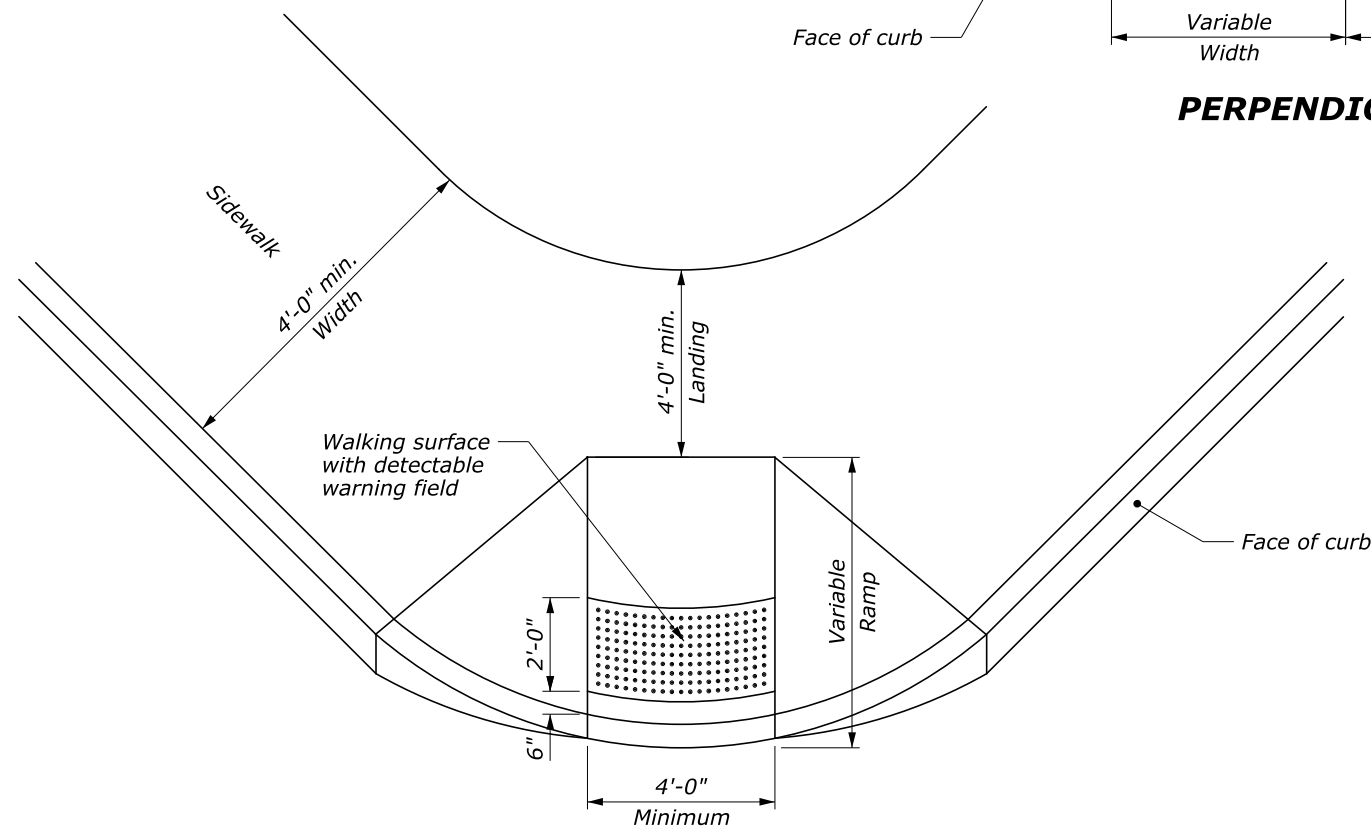

DIAGONAL CURB RAMP

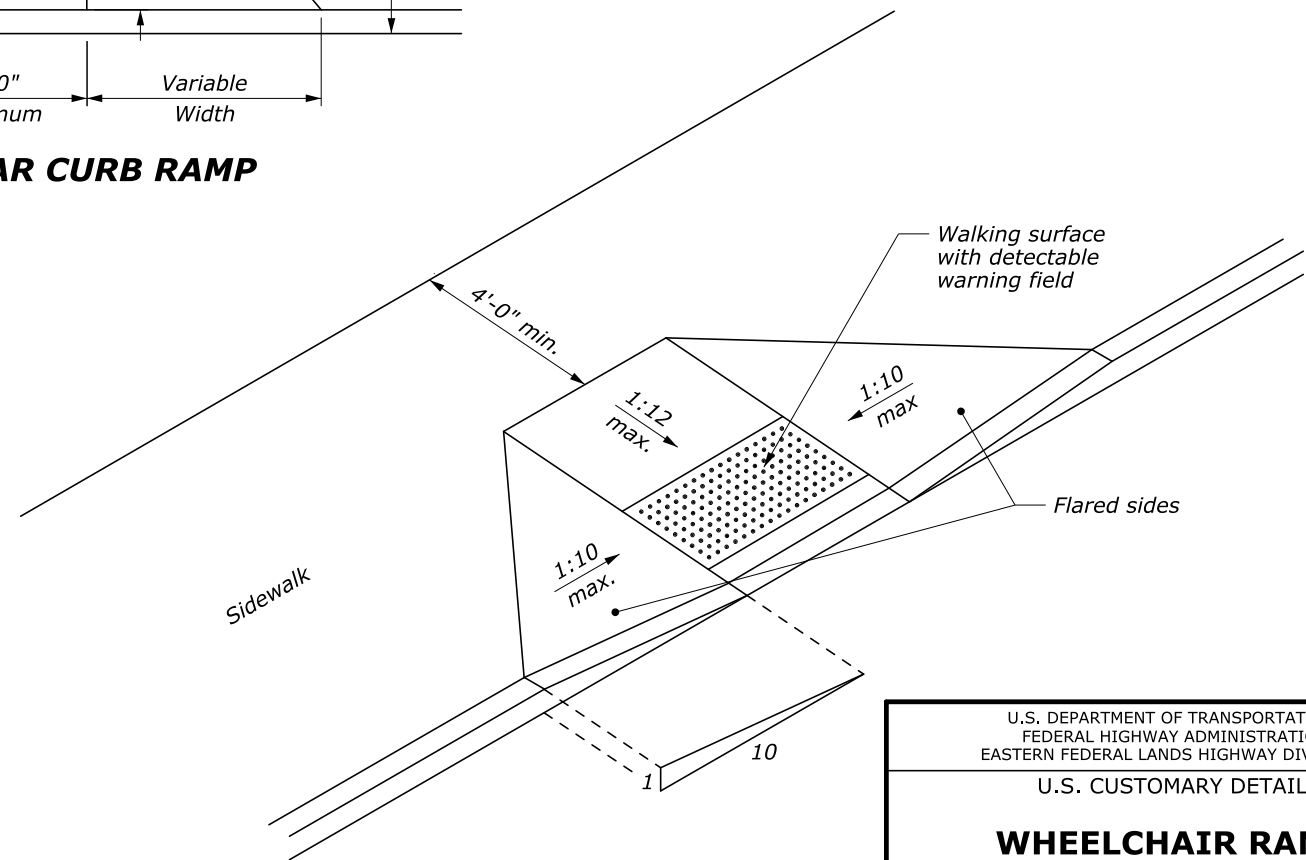

RAMP - ISOMETRIC

NOTE:

1. The maximum cross slopes of ramps must not exceed 2% in any direction.
2. Use a coarse broom finish running perpendicular to the slope to create a slip resistant surface on concrete ramp surfaces, exclusive of the detectable warning fields.
3. Construct curb ramp perpendicular to the curb. Avoid skewing the ramp face.
4. Construct ramp transitions between walks, gutters, or streets that are flush and free of abrupt vertical changes not to exceed 2.5 inches.
5. Locate drainage inlets and manholes outside of ramp walking surfaces or landings.

12-Feb-2019 08:47 AM M:\Standards_and_Details\EF\HD_Detail\Drawings\FP\H\Updates ET_Details 2-2019\6150-ET\TEMP.dgn

NO SCALE

U.S. DEPARTMENT OF TRANSPORTATION
FEDERAL HIGHWAY ADMINISTRATION
EASTERN FEDERAL LANDS HIGHWAY DIVISION

U.S. CUSTOMARY DETAIL

WHEELCHAIR RAMP CURB CUT

REVISED: 1/2004 2/2019

DETAIL
ET 615-1