

POST AND BLOCK

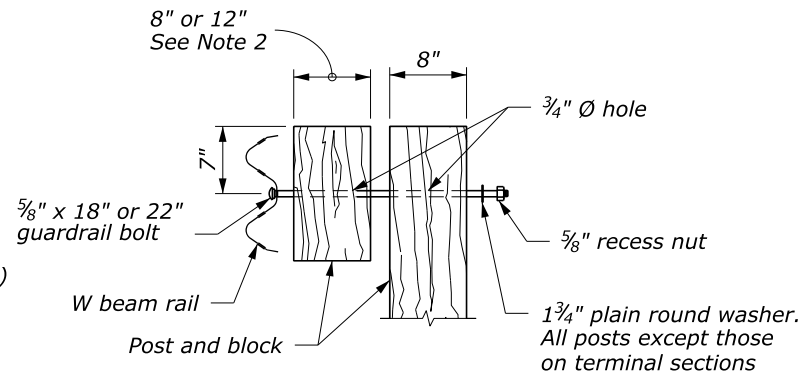

POST BOLT ASSEMBLY

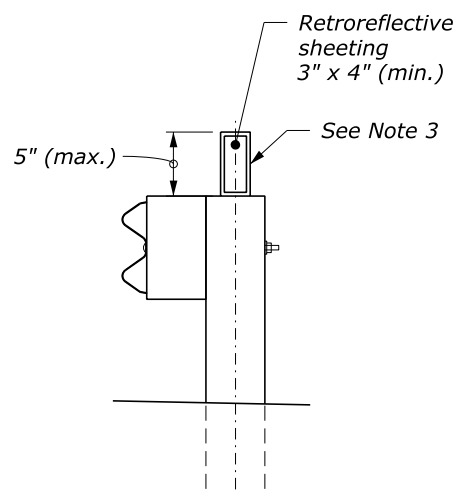

FLEXIBLE DELINEATOR GUARDRAIL MOUNT

NOTE:

1. When encountering impenetrable material, one post may be omitted in locations where the typical guardrail cross section includes 2-feet (min.) between the back of the guardrail post and the hinge point. For all other locations, see Section 617 and Details C617-13 or C617-37.
2. Size of block shown elsewhere on the plans. Use a single block or combination of blocks (no more than two) to achieve the actual 8-inch or 12-inch offset. Secure wood blocks to the posts with anti-rotation nails. If combination blocks are used, toenail the adjacent blocks with two 16d galvanized nails to prevent block rotation.
3. Install a flexible hinged delineator every fourth post. Fasten delineator to the top of the wood post using either an adhesive or mechanical means according to the manufacturer's recommendations. Match the color of the reflective element with the edge line. Other types of delineators may be used as approved by the CO.
4. In erodible or uncompacted soils, increase post length to 7'-6".
5. Dimensional tolerances not shown or implied are intended to be those consistent with the proper functioning of the part, including its appearance, and accepted manufacturing practices.

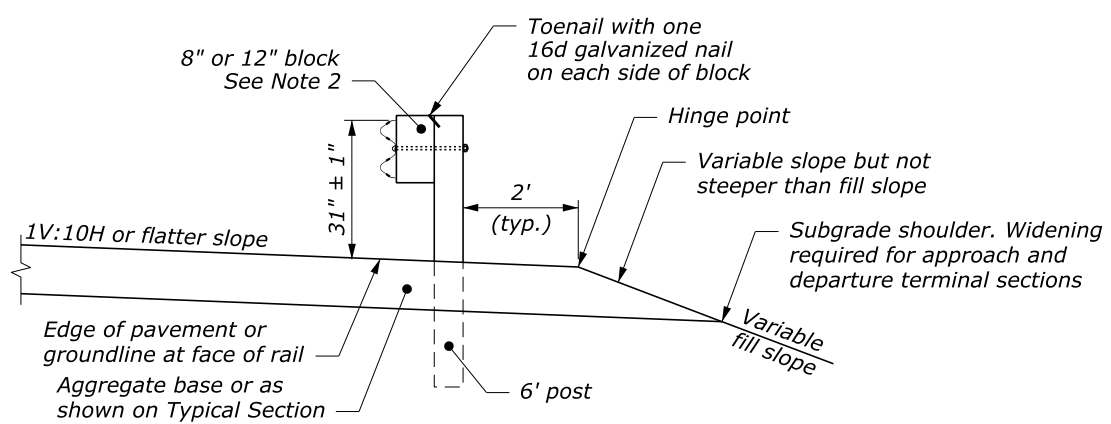

**TYPICAL GUARDRAIL CROSS SECTION
6' POST, 8" OR 12" BLOCK**

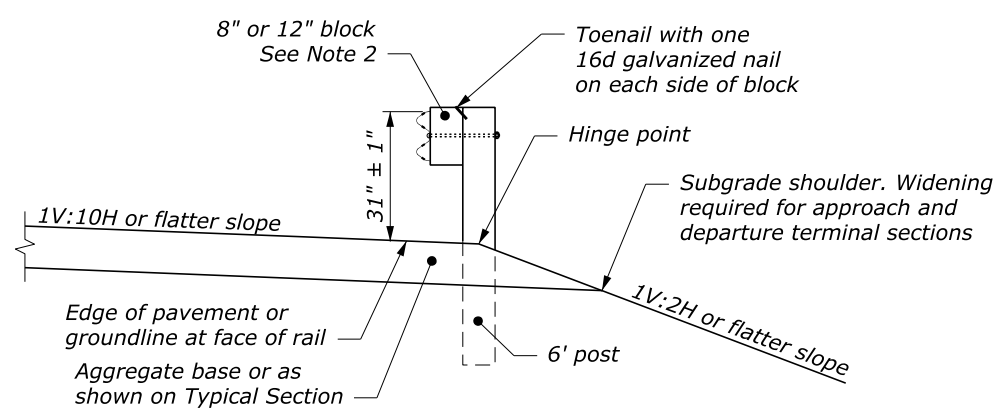

**TYPICAL GUARDRAIL CROSS SECTION
6' POST CENTERED ON HINGE, 8" OR 12" BLOCK
See Note 4**

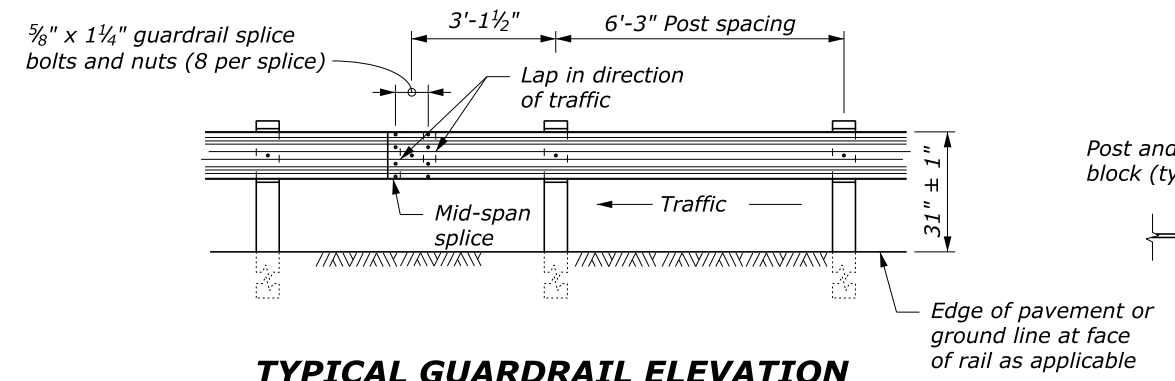

TYPICAL GUARDRAIL ELEVATION

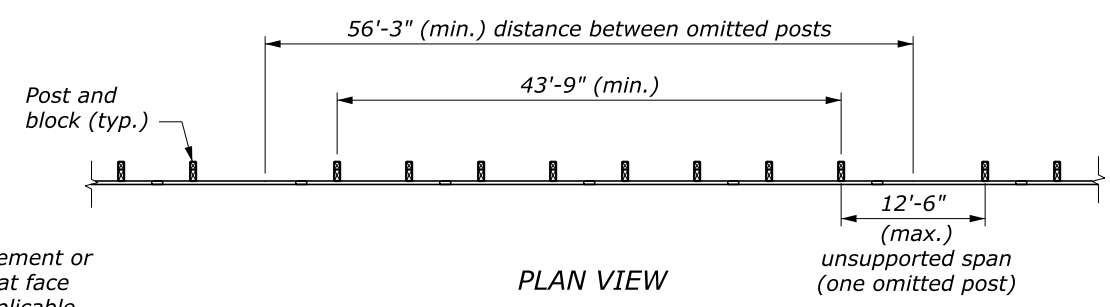

**PLAN VIEW
OMITTED POST DETAIL
See Note 1**

NO SCALE

U.S. DEPARTMENT OF TRANSPORTATION FEDERAL HIGHWAY ADMINISTRATION CENTRAL FEDERAL LANDS HIGHWAY DIVISION	
U.S. CUSTOMARY DETAIL	
MGS W-BEAM GUARDRAIL WOOD POSTS	
DETAIL APPROVED FOR USE 04/2020	DETAIL
REVISED:	C617-31

\$\$\$DATE\$\$\$
 \$\$\$TIME\$\$\$
 \$\$\$DGN\$\$\$
 \$\$\$USER\$\$\$

NOTES TO THE DESIGNER
Last Updated: April 2020

MGS W-Beam Guardrail, Wood Posts

General Information

Appropriate Applications.

- The Midwest Guardrail System (MGS) is a non-proprietary W-beam guardrail system that meets the current crash testing requirements. MGS is used when W-beam guardrail is selected for barrier installation.

Crash Test Criteria	MASH
Test Level	TL-3
FHWA Eligibility Letter	B-133, B-211A, B230A, B240
TF 13 Designator	SGR20a-b, SGR38a-e
Crash Test Report	Multiple MwRSF reports available at https://mwrsf.unl.edu/mgs.php



From MwRSF Report No. TRP-03-272-13

Limitations

- The drawing shows the various options for guardrail near slopes. When using wood posts, the preferred option is to use 6' post and 12" block with 2' between the back of post and the slope hinge point.

Layout Guidance.

- See AASHTO *Roadside Design Guide*
- Use the FLH Barrier Length of Need Calculator available at <https://flh.fhwa.dot.gov/resources/design/tools/Barrier-LON.xlsx>
- See the FLH *Midwest Guardrail System FAQ* document for more information.

Applicable SCRs

- Section 563 (if weathering agent applied to galvanized elements)
- Section 617
- Section 710
- Section 725 (if weathering agent applied to galvanized elements)

Typical Pay Item Used

- 61701-4550 Guardrail system MGS, type 2, class A wood posts [LNFT] for galvanized steel
- 61701-5150 Guardrail system MGS, type 4, class B wood posts [LNFT] for weathering steel

Updates

February 2019

- New Detail drawing

April 2020

- Revised notes, added color of delineator, revised some callouts